



MASTERTEMP® POOL AND SPA HEATER

[FOR OUTDOOR USE ONLY*] INSTALLATION AND USER'S GUIDE

240 VAC NATURAL GAS/LP GAS

MODELS Natural Propane

200HD (200 MJ/h)	460946	460949
300HD (300 MJ/h)	460945	460948
400HD (400 MJ/h)	460944	460947

FOR YOUR SAFETY – This product must be installed and serviced by authorized personnel, qualified in pool/spa heater installation. Improper installation and/or operation can create carbon monoxide gas and flue gases which can cause serious injury, property damage, or death. As an additional measure of safety, Pentair Aquatic Systems strongly recommends installation of suitable **Carbon Monoxide detectors** in the vicinity of this heater. Improper installation and/or operation will void the warranty.

Notice: MasterTemp™ Heaters are designed for use with Natural and Propane gas only.



**OWNER:
Retain For
Future
Reference**

(*) For heater indoor use, see page 17.

⚠ WARNING

FOR YOUR SAFETY - READ BEFORE OPERATING

- If you do not follow these instructions exactly, a fire or explosion may result, causing property damage, personal injury or loss of life.
- Improper installation, adjustment, alteration, service or maintenance can cause property damage, personal injury or death. Installation and service must be performed by a qualified installer, service agency or the gas supplier.
- Do not place articles or against this appliance.
- Do not use or store flammable materials near this appliance.
- Do not spray aerosols in the vicinity of this appliance while it is in operation.

WHAT TO DO IF YOU SMELL GAS

- Do not try to light any appliance.
- Do not touch any electrical switch; do not use any phone in your building.
- Immediately call your gas supplier from a neighbor's phone.
Follow the gas supplier's instructions.
- If you cannot reach your gas supplier, call the fire department.

For additional free copies of this manual; call AUS: 1300 137 344 - NZ: 0800 654 112.

Pentair Aquatic Systems AU/NZ – Head Office

1-21 Monash Drive, Dandenong South, Victoria 3175 – Australia • 1300.137.344 • Fax 1800.006.668

Pentair Aquatic Systems

1620 Hawkins Ave., Sanford, NC 27330, USA • (919) 566-8000 • (800) 831-7133
10951 W. Los Angeles Ave., Moorpark, CA 93021, USA • (805) 553-5000 • (800) 831-7133

Customer Service

If you have questions about ordering Pentair Water Pool and Spa, Inc. replacement parts, and pool products, please use the following contact information.

Customer Service and Technical Support, AUS

(9 AM - 5PM, Mon - Fri, Australia Wide)

Phone: 1300 137 344

Fax: 1800 006 668

New Zealand (9 AM - 5PM, Mon - Fri, NZST)

Phone: 0800 654 112

Fax: 0800 806 642

National Dealer Locator

Phone: 1 800 664 266

au.sales@pentair.com

Web sites

visit www.pentairpool.com.au

Pentair Water Pool and Spa, Inc. AU/NZ – Head Office:

1-21 Monash Drive, Dandenong South, Victoria 3175 – Australia • 1300.137.344 • Fax 1800.006.668

Pentair Water Pool and Spa, Inc. USA:

1620 Hawkins Ave., Sanford, NC 27330 – USA • (800) 831-7133 or (919) 566-8000

10951 West Los Angeles Ave., Moorpark, CA 93021 – USA • (800) 831-7133 or (805) 553-5000

Contents

Section 1. Heater Identification Information (HIN) 4
Heater Data Rating Plate 4

Section 2. Introduction 5
 Important Notices / Warranty Information 5
 Code Requirements 6
 Consumer Information and Safety Information 6 - 8
 General Specifications 8

Section 3. Installation 9
 Heater Description 9
 Sequence of Operation 9
 Putting the Heater into Service 9
 Specifications 10
 Plumbing Connections 11
 Valves 11
 Manual By-Pass 11
 Water Connections 12
 Below Pool Installation 12
 Gas Connections 13
 Gas Pipe Sizing 13
 Sediment Trap/Drip Leg 13
 Testing Gas Leaks and Gas Pressure 14
 Inlet Gas Pressure Requirements 15
 Outdoor Installation / Heater Clearances 15 - 16
 Indoor Venting—General Requirements Heater Clearances / Outside Vent Removal) 17
 Combustion Air Supply / Corrosive Vapors and Possible Causes 18
 Vent Installation (Indoor Installation or Outdoor Shelter) - Vertical Venting 18-21
 Horizontal or Vertical Venting - Using Single-Wall Stainless Gas Vent 21
 Connecting Single-Wall Stainless Steel Vent to the Heater 22
 Direct Air Intake Duct with 3-inch PVC Pipe (Indoor Installation) 23
 Horizontal or Vertical Venting Flexible Duct (Flex-Vent) 24
 Corrosive Vapors and Possible Causes 25
 Control Panel Indexing 25
 Final Installation Check 25
 Electrical Connections 26
 Fireman’s Switch Connection/Remote Control Connections 27
 MasterTemp Wiring Diagram / Electrical Schematic Ladder Diagram 28 - 29

Section 4. Operation 30
 Basic System Operation / HSI (Hot-Surface Ignition) Lighting/Operation 30
 Operating Instructions 31
 To Turn Off Gas to Appliance 31
 Safety Controls (Air Flow Switch / Water Pressure Switch / High Limits / Operation of Ignition Module) 32 - 33
 Operating the Control Panel / Temperature Setting / Maximum Temperature Set Point 33

Section 5. Troubleshooting 35
 Initial Troubleshooting and Troubleshooting Chart 35
 Heater Will Not Fire Troubleshooting (A, B, C, D, E) 36 - 39
 LED Diagnostics (AGS, AFS, HLS, PS Thermistor) 40 - 41
 Burner / Heat Exchanger Troubleshooting 42

Section 6. Maintenance 42
 Care and Maintenance 42
 Checking the Gas Control Valve 43
 DeLiming the Heater - Pressure Relief Valve 43
 After Start-Up 44
 Spring, Fall (Autumn) and Winter Operation 44
 Maintaining Pool Temperature / Energy Saving Tips 45
 Chemical Balance 45 - 46
 Replacement Parts 47 - 51

Heater Identification Information (HIN)

To identify the heater, see the data rating plate on the inner front panel of the heater. There are two designators for each heater, one is the Model Number and the other is the Heater Identification Number (HIN).

Heater Identification Number (HIN)

The following *example* simplifies the identification system:

- 1) **MT** : MasterTemp
- 2) **Model Size** : (200, 300 or 400) : Input rating (Mega Joule [MJ]/hr)
- 3) **Construction** : (HD = Heavy Duty Model)
- 4) **Fuel Type** : (LP = Propane gas or N = Natural gas)

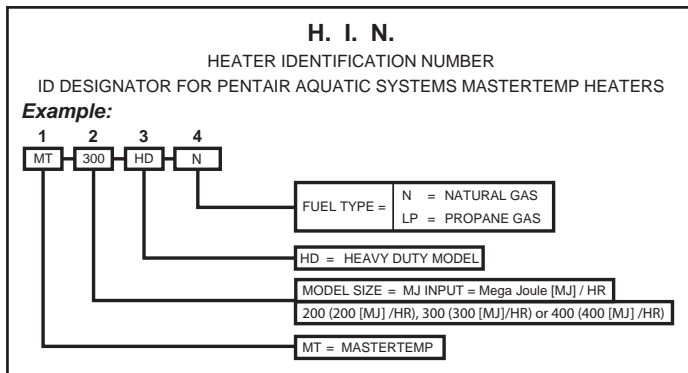

Heater Data Rating Plate

The heater data rating plate is located on the inner front panel of the heater. To access the data rating plate, unbolt and remove the side door access panel as shown below.

Heater Data Rating Plate Location

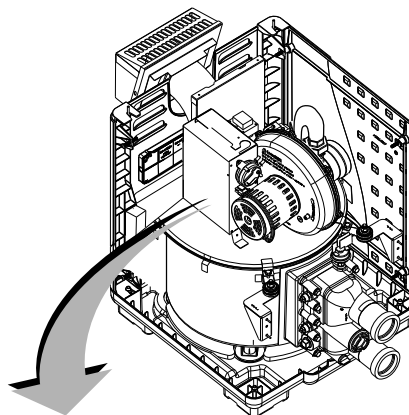
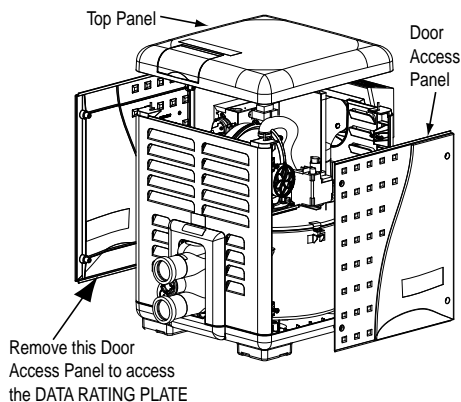

DESIGNED AND MANUFACTURED BY

PENTAIR
1620 Hawkins Ave.
Sanford, NC, USA 27330
AUS PH # +61 3 9574-4000

POOL HEATER

MASTERTEMP™

FOR YOUR SAFETY
Do not store or use gasoline or other flammable vapors and liquids in the vicinity of this or any other appliance.

IAPMO-RAT
OCEANA
GAS MARK
GMK10016
AS4560

MODEL NO. _____ SERIAL NO. _____	THIS HEATER EQUIPPED TO BURN NATURAL GAS INPUT RATE (MAX.) 400 MJ/Hr
MAX INLET GAS PRESS _____ MIN INLET GAS PRESS _____ TEST POINT PRESSURE _____ MAX WORKING PRESSURE _____	OUTPUT _____ ALTITUDE _____ ELECTRICAL CERTIFICATE OF SUITABILITY NO. _____
ELECTRICAL RATING: VOLTS _____ HERTZ _____ AMPS _____ ORIFICE SIZE _____	MINIMUM THERMAL EFFICIENCY 76 PERCENT MINIMUM CLEARANCE FROM COMBUSTIBLE CONSTRUCTION, 15 cm SIDE, 15 cm REAR, 110 cm TOP DO NOT INSTALL THIS HEATER UNDER AN OVERHANG LESS THAN 1 METER FROM THE TOP, THE AREA UNDER THE OVERHANG MUST BE OPEN ON THREE SIDES.
APPROVED FOR OUTDOOR INSTALLATION ONLY. ELECTRICAL COMPLIANCE: IN ACCORDANCE WITH AS/NZS 3000.	THIS APPLIANCE HAS AN IPX3 RATING AND MUST BE INSTALLED IN ACCORDANCE WITH THE AUSTRALIAN STANDARD AS/NZS 3000. REFER TO THE OPERATING INSTRUCTIONS FOR APPROVED WATER TREATMENTS.

THIS APPLIANCE MUST BE INSTALLED IN ACCORDANCE WITH THE AUSTRALIAN STANDARD AS/NZ 5601.1-2010 INSTALLATION CODES, AND WITH THE REQUIREMENTS OF THE AUTHORITY HAVING JURISDICTION.

*SEE INSTALLATION MANUAL

Introduction

MasterTemp™ Pool and Spa Heater

Congratulations on your purchase of a MasterTemp high performance heating system. Proper installation and service of your new heating system and correct chemical maintenance of the water will ensure years of enjoyment. The MasterTemp is a compact, lightweight, efficient, induced-draft, gas fired high performance pool and spa heater that can be directly connected to 50 mm PVC pipe. The MasterTemp also comes equipped with the Pentair Aquatic Systems multifunction temperature controller which shows, at a glance, the proper functioning of the heater. All MasterTemp heaters are designed with a direct ignition device, HSI (hot-surface ignition), which eliminates the need for a standing pilot. The MasterTemp requires an external power source (230-240 VAC, 50 Hz) to operate.

SPECIAL INSTRUCTIONS TO OWNER: Retain this manual for future reference. This instruction manual provides operating instructions, installation and service information for the MasterTemp high performance heater. The information in this manual applies to all MasterTemp models. **READ AND REVIEW THIS MANUAL COMPLETELY**, it is very important that the owner/installer read and understand the section covering installation instructions, and recognize the local and state codes before installing the MasterTemp. Its use will reduce service calls and chance of injury and will lengthen product life. History and experience has shown that most heater damage is caused by improper installation practices.

IMPORTANT NOTICES

THE MASTERTEMP HEATER MUST BE INSTALLED BY A REGISTERED INSTALLER OR A QUALIFIED GAS PLUMBER AND SERVICED BY A PROFESSIONAL SERVICE TECHNICIAN, QUALIFIED IN POOL HEATER INSTALLATION. SUCH INSTALLATION WILL COMPLY WITH CODE REQUIREMENTS LISTED ON PAGE 6.

NOTICE: THE MASTERTEMP HEATER IS INTENDED FOR INSTALLATION WITH A METERED GAS PRESSURE REGULATOR CAPABLE OF DELIVERING 1.0 - 6.0 kPa GAS PRESSURE TO THE MASTERTEMP GAS VALVE.

For the installer and operator of the MasterTemp pool and spa heater: The manufacturer's warranty may be void if, for any reason, the heater is improperly installed and/or operated. Be sure to follow the instructions set forth in this manual. If you need more information or if you have any questions regarding to this pool heater, please contact Pentair Aquatic Systems AU/NZ, AUS – at 1300 137 344 or + 61 3 9709 5800.

WARRANTY INFORMATION

The MasterTemp pool heater is sold with a limited factory warranty.

High standards of excellence include a policy of continuous product improvement results in your state-of-the-art heater. We reserve the right to make improvements which change the specifications of the heater without incurring an obligation to update the current heater equipment.

These heaters are designed for the heating of chlorine, bromine or salt system swimming pools and spas or in non-stationary installations, and should never be employed for use as space heating boilers or general purpose water heaters. The manufacturer's warranty may be void if, for any reason, the heater is improperly installed and/or operated. Be sure to follow the instructions set forth in this manual.

CAUTION

OPERATING THIS HEATER CONTINUOUSLY AT WATER TEMPERATURE BELOW 20° C. WILL CAUSE HARMFUL CONDENSATION AND WILL DAMAGE THE HEATER AND VOID THE WARRANTY. Do not use the heater to protect pools or spas from freezing if the final maintenance temperature desired is below 20° C., as this will cause condensation related problems.

CODE REQUIREMENTS

Installation must be in accordance with the following:

- Manufacturer's Installation Instructions
- AS/NZS 5601.1 for Gas Installations
- Local Gas Fitting Regulations,
- Municipal Building Codes,
- S.A.A. Wiring Code,
- Local Electrical Regulations
- Any other statutory regulations
- SANS 10087-1 or SANS 827



DANGER

CARBON MONOXIDE GAS IS DEADLY – Exhaust from this pool heater contains toxic levels of carbon monoxide, a dangerous, poisonous gas you cannot see or smell.

CONSUMER INFORMATION AND SAFETY

WARNING

The U.S. Consumer Product Safety Commission warns that carbon monoxide is an "invisible killer". Carbon monoxide is a colorless and odorless gas.

1. Carbon monoxide is produced by burning fuel, including natural gas and propane.
2. Proper installation, operation and maintenance of fuel-burning appliances in the home is the most important factor in reducing carbon monoxide poisoning.
3. Be sure that fuel burning appliances such as heaters are installed by professionals according to manufacturer's instructions and codes.
4. Always follow the manufacturer's directions for safe operation.
5. Have the heating system (including vents) inspected and serviced annually by a trained service technician.
6. Examine vents regularly for improper connections, visible cracks, rust or stains.
7. Install battery-operated carbon monoxide alarms. The alarms should be certified to the requirements of the most recent UL, IAS, CSA and IAPMO standard for carbon monoxide alarms. Test carbon monoxide alarms regularly and replace dead batteries.

WARNING

The U.S. Consumer Product Safety Commission warns that elevated water temperature can be hazardous. See below for water temperature guidelines before setting temperature.

1. Spa or hot tub water temperatures should never exceed 40° C. A temperature of 37° C. is considered safe for a healthy adult. Special caution is suggested for young children. Prolonged immersion in hot water can induce hyperthermia.
2. Drinking of alcoholic beverages before or during spa or hot tub use can cause drowsiness which could lead to unconsciousness and subsequently result in drowning.
3. Pregnant women beware! Soaking in water above 37° C. can cause fetal damage during the first three months of pregnancy (resulting in the birth of a brain-damaged or deformed child). Pregnant women should stick to the 37° C. maximum rule.
4. Before entering the spa or hot tub, the user should check the water temperature with an accurate thermometer. Spa or hot tub thermostats may err in regulating water temperatures by as much as 3° C.
5. Persons with a medical history of heart disease, circulatory problems, diabetes or blood pressure problems should obtain their physician's advice before using spas or hot tubs.
6. Persons taking medication which induce drowsiness, such as tranquilizers, antihistamines or anticoagulants should not use spas or hot tubs.

WARNING

Should overheating occur or the gas supply fail to shut off, turn off the manual gas control valve to the heater. Do not use this heater if any part has been under water. Immediately call a qualified service technician to inspect the heater and to replace any part of control system and gas control which has been under water.

SAFETY INFORMATION

The MasterTemp pool heaters are designed and manufactured to provide many years of safe and reliable service when installed, operated and maintained according to the information in this manual. Throughout the manual, safety warnings and cautions are identified by the “” symbol. Be sure to read and comply with all of the warnings and cautions.

DANGER — CARBON MONOXIDE GAS IS DEADLY

•• READ OWNERS MANUAL COMPLETELY BEFORE OPERATING. ••

THIS PRODUCT MUST BE INSTALLED AND SERVICED BY A PROFESSIONAL SERVICE TECHNICIAN, QUALIFIED IN POOL HEATER INSTALLATION. Some jurisdictions require that installers be licensed. Check with your local building authority about contractor licensing requirements. Improper installation and/or operation could create carbon monoxide gas and flue gases which could cause serious injury or death. Improper installation and/or operation will void the warranty.

Exhaust from this pool heater contains carbon monoxide, a dangerous, poisonous gas you cannot see or smell. Symptoms of carbon monoxide exposure or poisoning include dizziness, headache, nausea, weakness, sleepiness, muscular twitching, vomiting and inability to think clearly. IF YOU EXPERIENCE ANY OF THE ABOVE SYMPTOMS, IMMEDIATELY TURN OFF THE POOL HEATER, LEAVE THE VICINITY OF THE POOL OR SPA AND GET INTO FRESH AIR IMMEDIATELY. THE POOL HEATER MUST BE THOROUGHLY TESTED BY A GAS PROFESSIONAL BEFORE RESUMING OPERATION.

EXCESSIVE CARBON MONOXIDE EXPOSURE CAN CAUSE BRAIN DAMAGE OR DEATH.

Install this pool heater far from open windows, doors, vents and other openings, see [page 16](#) for minimum distances.

Pentair strongly recommends that all vents, pipes and exhaust systems be initially and periodically tested for proper operation. This testing can be accomplished by using a hand-held carbon monoxide meter and/or by consulting with a gas professional.

Pool heaters must be used in conjunction with carbon monoxide detectors installed near the pool heater. The carbon monoxide detectors must be periodically inspected for proper operation so as to insure continued safety. Broken or malfunctioning carbon monoxide detectors must be replaced immediately.

 **WARNING** — This heater is equipped with an unconventional gas control valve that is factory set with a manifold pressure of **11 ± 5 Pa**. Improper installation, adjustment, alteration, service or maintenance can cause property damage, personal injury or loss of life. Installation or service must be performed by a qualified installer, service agency or the gas supplier. If this control is replaced, it must be replaced with an identical control.

Do not attempt to adjust the gas flow by adjusting the regulator setting.

 **WARNING** — **Risk of fire or explosion from incorrect fuel use or faulty fuel conversion.** Do not try to run a heater set up for natural gas on propane gas or vice versa. Only qualified service technicians should attempt to convert heater from one fuel to the other. Do not attempt to alter the rated input or type of gas by changing the orifice. If it is necessary to convert to a different type of gas, consult your Pentair dealer. Serious malfunction of the burner can occur which may result in loss of life. Any additions, changes, or conversions required in order for the appliance to satisfactorily meet the application needs must be made by a Pentair dealer or other qualified agency using factory specified and approved parts. The heater is available for use with natural gas or LP (propane) gas only. It is not designed to operate with any other fuels. Refer to the nameplate for the type of gas the heater is equipped to use.

- Use heater only with the fuel for which it is designed.
- If a fuel conversion is necessary, refer this work to a qualified service technician or gas supplier before putting the heater into operation.

SAFETY INFORMATION, (cont'd.)

⚠ WARNING — **Risk of fire or explosion from flammable vapors.** Do not store gasoline, cleaning fluids, varnishes, paints, or other volatile flammable liquids near heater.

⚠ WARNING — **Risk of explosion if unit is installed near propane gas storage.** Propane (LP) gas is heavier than air. Consult local codes and fire protection authorities about specific installation requirements and restrictions. Locate the heater away from propane gas storage and filling equipment as specified by the Standard for the Storage and Handling of Liquefied Petroleum Gases (latest edition).

⚠ WARNING — **Risk of fire.** Do not place articles on, near or against the heater.

⚠ WARNING — **Risk of burn hazard.** To reduce the risk of injury, do not touch the side heater vent cover when the heater is operating. Side heater vent covers are HOT and can burn when touched causing personal injury. Do not allow children to play on or around heater or associated equipment.

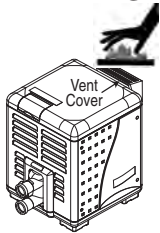

⚠ WARNING — **Risk of asphyxiation if exhaust is not correctly vented. Follow venting instructions exactly when installing heater.** Do not use a draft hood with this heater, as the exhaust is under pressure from the burner blower and a draft hood will allow exhaust fumes to blow into the room housing the heater. The heater is supplied with an integral venting system for outdoor installation.

⚠ CAUTION — **Label all wires prior to disconnection when servicing controls. Wiring errors can cause improper and dangerous operation. Wiring errors can also destroy the control board.**

- Connect heater to **230-240 Volt, 50 Hz., Single Phase** power only.
- Verify proper operation after servicing.
- Do not allow children to play on or around heater or associated equipment.
- Never allow children to use the pool or spa without adult supervision.
- Read and follow other safety information contained in this manual prior to operating this pool heater.

GENERAL SPECIFICATIONS

NOTICE:

- Combustion air contaminated by corrosive chemical fumes can damage the heater and will void the warranty.
- The Combination Gas Control Valve on this heater differs from most appliance gas controls. If it must be replaced, for safety reasons replace it only with an identical gas control.
- The access door panels must be in place to provide proper ventilation. Do not operate the heater for more than five (5) minutes with the access door panels removed.
- This heater is design certified by IAPMO as complying with the Standard for Gas Fired Pool Heaters, and is intended for use in heating fresh water swimming pools or spas.
- The heater is designed for the heating of chlorine, bromine or salt system swimming pools and spas. It should **NOT** be used as a space heating boiler, or general purpose water heater. The heater requires an external **230-240 VAC** single-phase electric power source.
- The heater should be located in an area where leakage of the heater or connections will not result in damage to the area adjacent to the heater or to the structure. When such locations cannot be avoided, it is recommended that a suitable drain pan, adequately drained, be installed under the heater. The pan must not restrict air flow.
- The heater may not be installed within 3.5M (11.5 ft.) of the inside surface of a pool or spa unless it is separated by a solid fence, wall or other permanent barrier.

Installation Instructions

THIS PRODUCT MUST BE INSTALLED AND SERVICED BY A PROFESSIONAL SERVICE TECHNICIAN, QUALIFIED IN POOL HEATER INSTALLATION.

Pentair strongly recommends that all vents, pipes and exhaust systems be initially and periodically tested for proper operation. This testing can be accomplished by using a hand-held carbon monoxide meter and/or by consulting with a gas professional.

Pool heaters must be used in conjunction with carbon monoxide detectors installed near the pool heater. The carbon monoxide detectors must be periodically inspected for proper operation so as to insure continued safety. Broken or malfunctioning carbon monoxide detectors must be replaced immediately.

HEATER DESCRIPTION

Figure 1 is a diagram of the heater showing how it operates. Precisely matched orifice plates meter the air and gas into the mixer. The blower draws the air and gas through the mixer and forces it into the burner's flame holder. A sealed heat exchanger surrounds the flame holder, discharging exhaust gases out the flue.

50 mm PVC water piping connects directly to the manifold/header on the heat exchanger using 50 mm PVC slip unions provided with the heater. The outer manifold remains cool; no heat sinks are required. A thermal regulator and an internal bypass regulate the water flow through the heat exchanger to maintain the correct outlet temperature. The heater operator control panel board assembly is located on top of the heater.

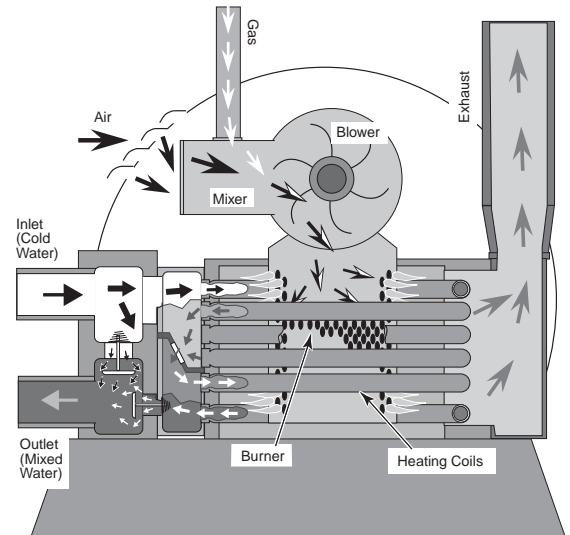

Figure 1.

SEQUENCE OF OPERATION

An electronic temperature sensing **thermistor** in the manifold adapter inlet controls the heater operation. When the inlet water temperature drops below the temperature set on the **operating control**, the **burner controller** supplies power to the combustion **air blower** through a series of **safety interlocks**. The interlocks consist of:

- the **pressure switch (PS)**, which senses that the pump is running,
- the **high limit switch (HLS)**, which opens if the heat exchanger outlet temperature goes above 55° C (131° F), and
- the **air flow switch (AFS)**, which senses the pressure drop across the air metering orifice,
- the **automatic gas shut-off (AGS) switch**, which opens if the heat exchanger outlet temperature goes above 60° C (140° F).
- the **inlet temperature control switch**, which opens if the inlet temperature goes above 45° C (110° F).
- the **stack flue sensor (SFS)**, which shuts down the heater if the flue gas temperature reaches 249° C (480° F).

The air flow switch (AFS) senses the pressure drop across the air metering orifice. As soon as there is sufficient air flow, the AFS closes, closing the circuit to the **hot surface igniter (HSI)**, which ignites the fuel mixture. On a call for heat, the blower and HSI are energized. In about 20 seconds, the gas valve opens and ignition occurs. The HSI then switches to a sensing mode and monitors the flame.

The heater is equipped with a digital operating control that enables the user to pre-set the desired pool and spa water temperatures. The control enables the user to select between pool and spa heating, and features a digital display that indicates the water temperature.

PUTTING THE HEATER INTO SERVICE

If the heater is installed below the level of the pool, or more than 0.6 meters (2 feet) above pool level, the pressure switch setting should be adjusted. See "WATER PRESSURE SWITCH" in the "SAFETY CONTROLS Section" (page 32) and the "CAUTION" under "BELOW POOL INSTALLATION Section" (page 12).

Before putting the heater into service for the first time, follow the instructions under "BEFORE START-UP" (page 30) in the front of this manual. Check for proper operation of the heater by following the steps under "OPERATION INSTRUCTIONS." Damage to equipment caused by improper installation or repair will void the warranty.

SPECIFICATIONS

These installation instructions are designed for use by qualified personnel only, trained especially for installation of this type of heating equipment and related components. Some states require installation and repair by licensed personnel. If this applies in your state, be sure your contractor bears the appropriate license. See Figure 2 for Outdoor Installations.

DIMENSIONS IN CENTIMETERS & INCHES

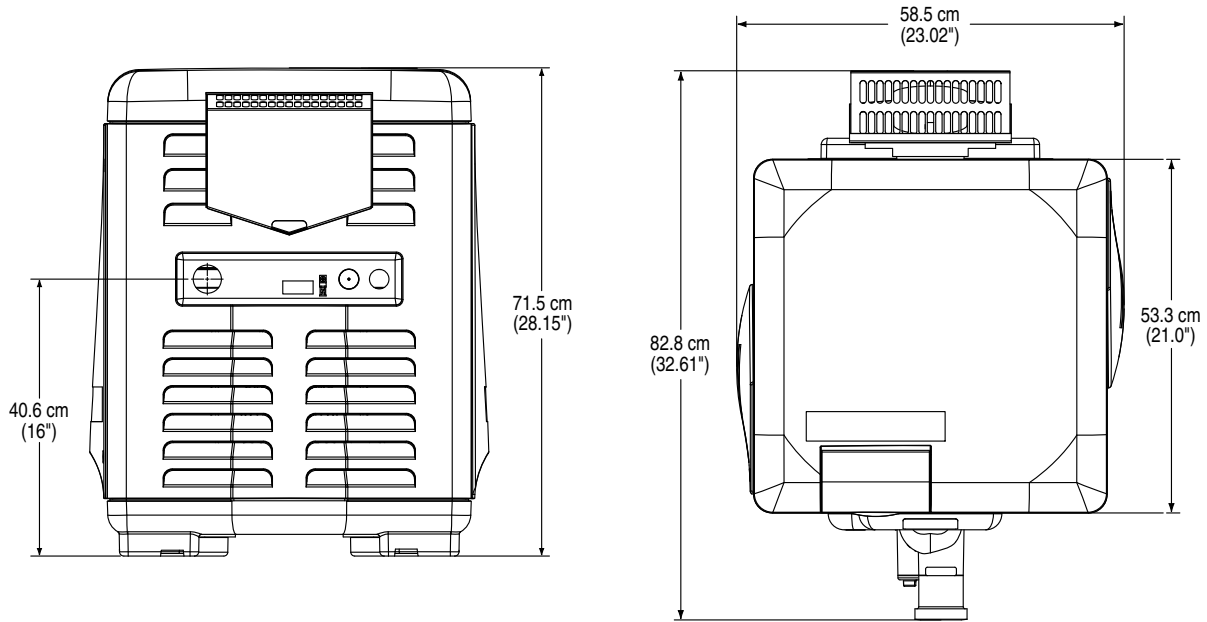

FRONT

TOP

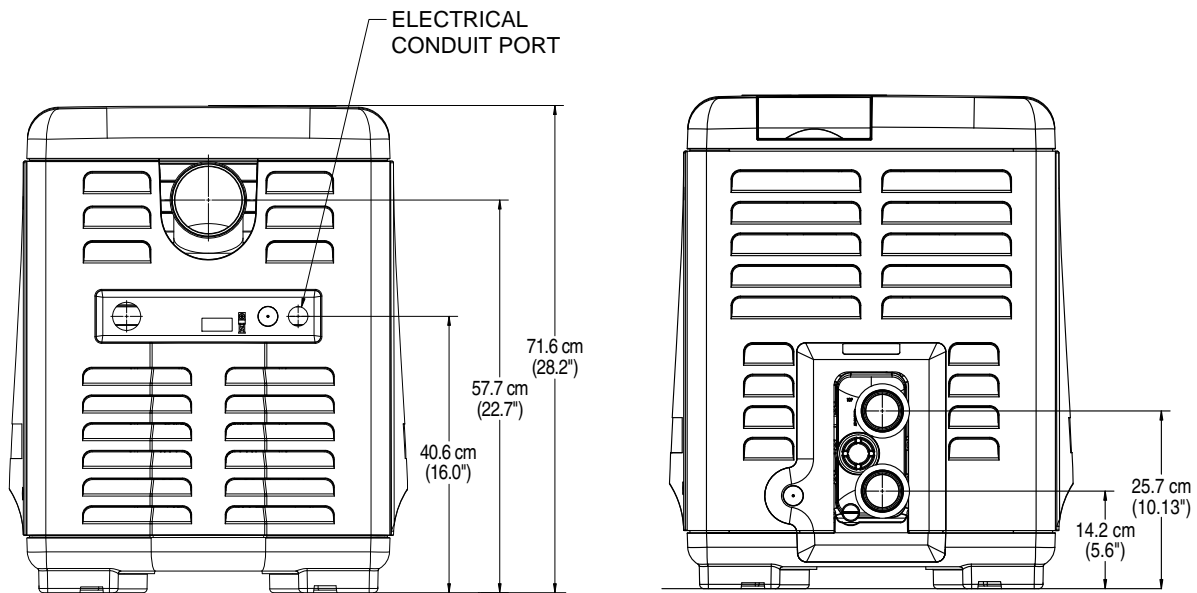

EXHAUST SIDE

PLUMBING SIDE

Figure 2.

PLUMBING CONNECTIONS

The MasterTemp heater has the unique capability of direct PVC plumbing connections. A set of bulkhead fittings is included with the MasterTemp to insure conformity with Pentair’s recommended PVC plumbing procedure. Other plumbing connections can be used. See Figure 3 for plumbing connections.

⚠ CAUTION

Before operating the heater on a new installation, turn on the circulation pump and bleed all the air from the filter using the air relief valve on top of the filter. Water should flow freely through the heater. Do not operate the heater unless water in the pool/spa is at the proper level. If a manual by-pass is installed, temporarily close it to insure that all air is purged from the heater.

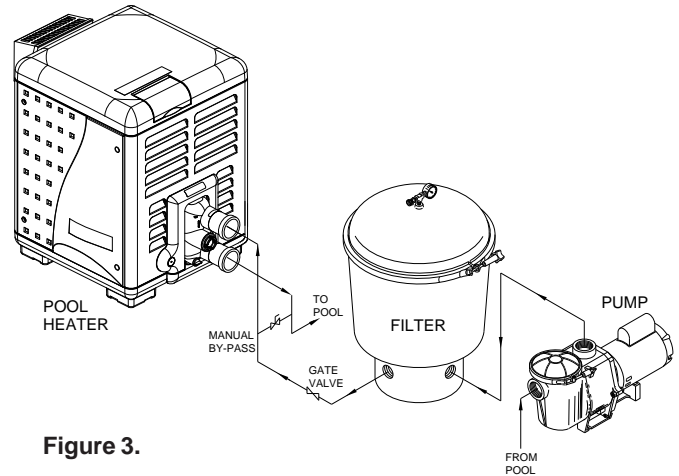

Figure 3.

VALVES

When any equipment is located below the surface of the pool or spa, valves should be placed in the circulation piping system to isolate the equipment from the pool or spa. Check valves are recommended to prevent back-siphoning. Back-siphoning is most likely to occur when the pump stops, creating a pressure-suction differential. Do **NOT** sanitize the pool by putting chlorine tablets or sticks into the skimmer(s). When the pump is off, this will cause a high concentration of chlorine to enter the heater, which could cause corrosion damage to the heat exchanger.

⚠ CAUTION

Exercise care when installing chemical feeders so as to not allow back siphoning of chemical into the heater, filters or pump. When chemical feeders are installed in the circulation of the piping system, make sure the feeder outlet line is down stream of the heater, and is equipped with a positive seal noncorrosive “Check Valve”, (P/N R172288), between the feeder and heater.

MANUAL BY-PASS (WATER FLOW RATE)

Where the water flow rate exceeds the maximum 454 LPM, a manual bypass should be installed and adjusted. After installing the valve, adjust the valve to bring the flow rate within the acceptable range. Then remove the valve handle or lock it in place to avoid tampering. See Figure 4.

Model	Min. (LPM)	Max. (LPM) *
200	160	454
300	200	454
400	240	454

* Do not exceed the maximum recommended flow rate for the connecting piping.

Table 1.

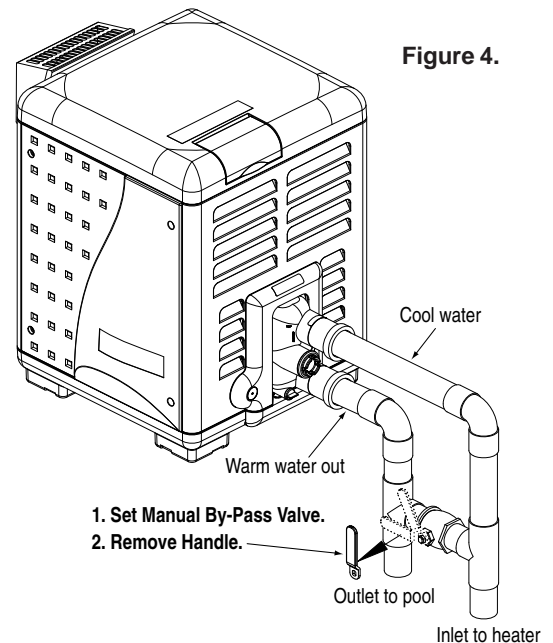

Figure 4.

See page 32 for Pressure Relief Valve Installations.

WATER CONNECTIONS

The heater requires proper water flow and pressure for its operation. See Figure 5 for the recommended installation. The filter pump discharges to the filter, the filter discharges to the heater, and the heater discharges directly to the pool or spa.

A manual bypass valve should be installed across the heater when the pump flow exceeds 454 LPM (120 GPM). See “WATER FLOW RATE” on page 11 - Table 1 for setting of the manual by-pass valve.

Make sure that the outlet plumbing from the heater contains no shut-off valves or other flow restrictions that could prevent flow through the heater (except for below pool as noted below, or winterizing valves where needed). To switch flow between the pool and spa, use a diverter valve. Do not use any valve that can shut off the flow. Do not use a shut-off valve to isolate the heater unless it is below the level of the pool or spa.

Install the chemical feeder downstream of the heater. Install a chemical resistant one-way check valve between the heater and the chemical feeder to prevent back-siphoning through the heater when the pump is off.

NOTICE: If the heater is plumbed in backwards, it will cycle continuously. Make sure piping from filter is not reversed when installing heater.

Connect the heater directly to 50 mm PVC pipe, using the integral unions provided. Heat sinks are not required. The low thermal mass of the heater will prevent overheating of the piping connected to the pump even if the heater shuts down unexpectedly.

Occasionally a two-speed pump will not develop enough pressure on the low speed to operate the heater. In this case, run the pump at high speed only to operate the heater. If this does not solve the problem, do not try to run the heater. Instead, correct the installation.

Do not operate the heater while an automatic pool cleaner is also operating. If the circulation pump suction is plugged (for example by leaves), there may not be adequate flow to the heater. Do not rely on the pressure switch in this case.

Local codes may require the installation of a pressure relief valve (PRV), see page 43 for “PRESSURE RELIEF INSTRUCTIONS”.

BELOW POOL INSTALLATION

If the heater is below water level, the pressure switch must be adjusted. This adjustment must be done by a qualified service technician.

See following **CAUTION** before installation.

⚠ CAUTION

BELOW OR ABOVE POOL INSTALLATION

The water pressure switch is set in the factory at 21 kPa (± 5 kPa). This setting is for a heater installed at pool level. If the heater is to be installed more than 0.3 m above or below, the water pressure switch must be adjusted by a qualified service technician. See page 32, Figure 22.

FLOW SWITCH

If the heater is installed more than 1.5 m above the pool or more than 1.2 m below the pool level, you will be beyond the limits of the pressure switch and a flow switch must be installed. Locate and install the flow switch externally on the outlet piping from the heater, as close as possible to the heater. Connect the flow switch wires in place of the water pressure switch wires.

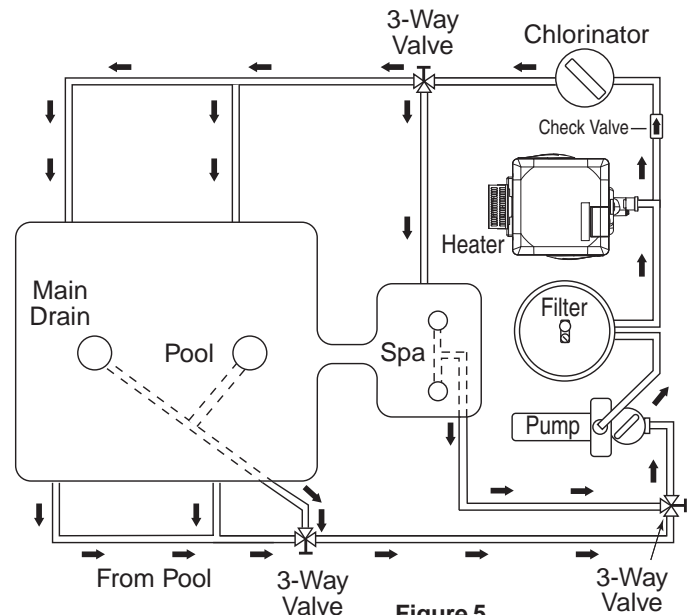

Figure 5.

GAS CONNECTIONS

GAS LINE INSTALLATIONS

The gas supply must be installed in accordance with the *Gas Installation Code, AS/NZS 5601.1*, as applicable and all applicable local codes.

Before installing the gas line, be sure to check which gas the heater has been designed to burn. This is important because different types of gas require different gas pipe sizes. The rating plate on the heater will indicate which gas the heater is designed to burn. Table 2 below shows the recommended gas inlet pipe sizes required for the distance from the gas meter to the heater. The table is for natural gas at a specific gravity of .65 and propane at a specific gravity of 1.55.

When sizing gas lines, calculate 0.9 additional meters of straight pipe for every elbow used. When installing the gas line, avoid getting dirt, grease or other foreign material in the pipe as this may cause damage to the gas valve, which may result in heater failure.

The gas meter should be checked to make sure that it will supply enough gas to the heater and any other appliances that may be used on the same meter. Insufficient gas supply will cause the heater to operate below its designed performance or not at all. The gas line from the meter will usually be of a larger size than the gas valve supplied with the heater. Therefore a reduction of the connecting gas pipe will be necessary. Make this reduction as close to the heater as possible. Gas supply companies are increasingly supplying natural gas to new installations with 2.75 kPa; this means if the gas pressure is not adjusted to the correct working pressure, the heater will be over gassed and cause serious damage within minutes. This damage is not covered under the heater warranty.

Install a manual shut-off valve that conforms with Type 1 or Type 2 as per AG201 and/or AS4617 standards, and a sediment trap/drip leg and union located outside the heater panels, see Figure 6. Do not use a restrictive gas cock.

The heater and any other gas appliances must be disconnected from the gas supply piping system during any pressure testing on that system, (greater than 6.0 kPa). The heater and its gas connection must be leak tested before placing the heater in operation. **Do not use flame to test the gas line.** Use soapy water or another nonflammable method.

NOTE

A manual main shut-off valve must be installed externally to the heater.

⚠ WARNING

DO NOT INSTALL THE GAS LINE UNION INSIDE THE HEATER CABINET. THIS WILL VOID YOUR WARRANTY.

GAS PIPE SIZING

Table 2.

Heater Size	Distance from the Meter		
	0 to 15 m	16 to 30 m	31 to 60 m
200	25 mm	32 mm	32 mm
300	32 mm	32 mm	40 mm
400	32 mm	40 mm	50 mm

INSTALLING A SEDIMENT TRAP/DRIP LEG

INSTALL A SEDIMENT TRAP/DRIP LEG AND UNION LOCATED OUTSIDE THE HEATER PANELS IN ACCORDANCE WITH NATIONAL CODE REQUIREMENTS. DO NOT USE A RESTRICTIVE GAS COCK. THE SEDIMENT TRAP/DRIP LEG SHALL BE EITHER A TEE FITTING WITH A CAPPED NIPPLE IN THE BOTTOM OUTLET WHICH CAN BE REMOVED FOR CLEANING, AS ILLUSTRATED IN FIGURE 6, OR AN OTHER DEVICE RECOGNIZED AS AN EFFECTIVE SEDIMENT TRAP/DRIP LEG. ALL GAS PIPING SHOULD BE TESTED AFTER INSTALLATION IN ACCORDANCE WITH LOCAL CODES.

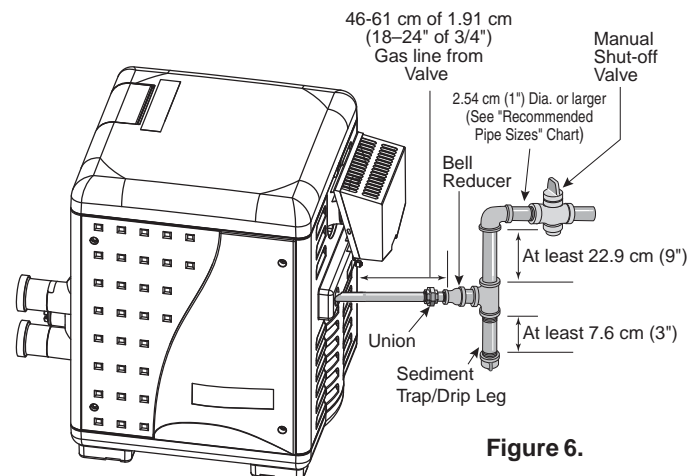

Figure 6.

TESTING GAS LEAKS AND GAS PRESSURE

Before operating the heater, the heater and its gas connections must be leak tested. **Do NOT use an open flame to test for leaks.** Test all gas connections for leaks with soapy water. The gas valve must be completely disconnected from the gas supply piping system during any pressure testing of that system at test pressures in excess of 6.0 kPa (.87 psig).

TESTING THE GAS PRESSURE THROUGH THE COMBINATION GAS CONTROL VALVE

⚠ WARNING

Risk of fire and explosion. Improper installation, incorrect adjustment, alteration, service, or maintenance of the Combination Gas Control Valve can lead to fire or explosion, causing loss of life, personal injury, and/or property damage. If it is necessary to adjust the gas valve, this must be done by only by a qualified service agency. These instructions are for the use of qualified service technicians only!

These instructions are for the use of qualified service technicians only!

1. Shut off the gas supply to the heater.
2. Loosen the small screw inside the pressure tap as shown in
3. Connect the manometer hose.
4. Open the gas supply to the heater.
5. Turn on the heater.
6. Take the gas pressure reading.
7. Turn off the heater.
8. Shut off the gas supply to the heater.
9. Disconnect the manometer hose.
10. Tighten the small screw inside the pressure tap.
11. Open the gas supply to the heater.
12. Verify that the seal connection in the pressure tap is closed by testing for leaks with soapy water. **Note:** If the pressure reading is out of range, (see **Table 3 on next page**), regulate the incoming gas pressure.

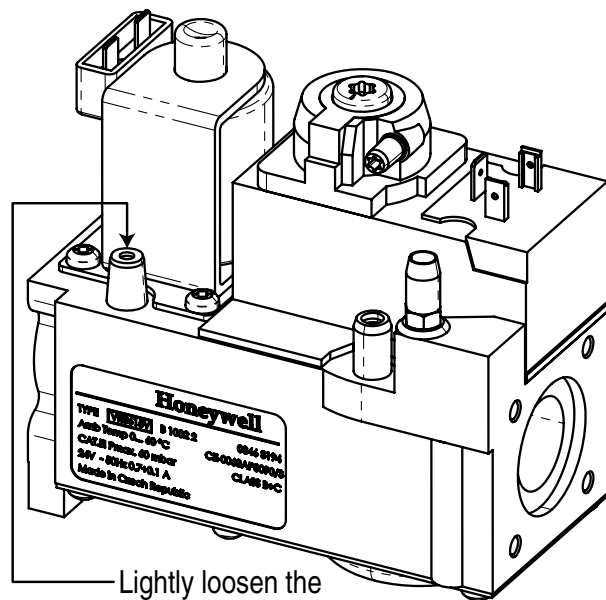

— Lightly loosen the small screw inside the pressure tap and then attach/connect the manometer hose.

Figure 7.

NOTE: “SEE MAINTENANCE SECTION, PAGE 43 FOR “CHECKING THE GAS CONTROL VALVE”

INLET GAS PRESSURE REQUIREMENTS

Gas Pressure	Minimum	Maximum
Natural Gas	1.13 kPa	6.0 kPa
Propane Gas	2.75 kPa	6.0 kPa

NOTE: The minimum value approved for input adjustment. Do not exceed the maximum supply pressure. All readings must be taken while heater is operating. Any adjustments or readings made while heater is off will result in performance problems.

Table 3.

OUTDOOR INSTALLATION (Australia)

For heaters located outdoors, using the built-in stackless venting system.

⚠ DANGER

CARBON MONOXIDE GAS IS DEADLY – Exhaust from this pool heater contains carbon monoxide, a dangerous, poisonous gas you cannot see or smell. Symptoms of carbon monoxide exposure or poisoning include dizziness, headache, nausea, weakness, sleepiness, muscular twitching, vomiting and inability to think clearly. IF YOU EXPERIENCE ANY OF THE ABOVE SYMPTOMS, IMMEDIATELY TURN OFF THE POOL HEATER, LEAVE THE VICINITY OF THE POOL OR SPA AND GET INTO FRESH AIR IMMEDIATELY. THE POOL HEATER MUST BE THOROUGHLY TESTED BY A GAS PROFESSIONAL BEFORE RESUMING OPERATION.

EXCESSIVE CARBON MONOXIDE EXPOSURE CAN CAUSE BRAIN DAMAGE OR DEATH.

⚠ WARNING

Risk of explosion if a unit burning propane gas is installed in a pit or other low spot. Propane is heavier than air. Do not install the heater using propane in pits or other locations where gas might collect. Consult your local building code officials to determine installation requirements and specific installation restrictions of the heater relative to propane storage tanks and filling equipment. Installation must meet the requirements for the Standard for the Storage and Handling of Liquid Petroleum Gases. Consult local codes and fire protection authorities about specific installation restrictions.

Locate the heater in an open, unroofed area and on a level surface that is protected from drainage or run-off. Install the heater in an area where leaves or other debris will not collect on or around the heater.

It is recommended that a non-combustible base be a platform under the heater constructed of hollow masonry blocks, not less than 100 millimeters (mm) thick (laid with ends unsealed and joints matched for air circulation). Cover blocks with 0.75 mm (min.) galvanized sheet metal, see [Figure 8](#).

To avoid damage to the electronic components in the heater, take care to prevent prolonged exposure to driving sources of water (such as lawn sprinklers, heavy roof runoff, hoses, etc.). Avoid operation in persistent, extreme, moist or salty environments. In extreme weather, shut down the heater and disconnect the power to it until the weather has moderated. In areas subject to hurricanes or very high winds, purchase the Bolt Down Bracket Kit, P/N 460738, see [Figure 9](#).

Note 1: DO NOT locate the heater where it is exposed to a prevailing wind.

Note 2: Be sure the heater is level with the ground.

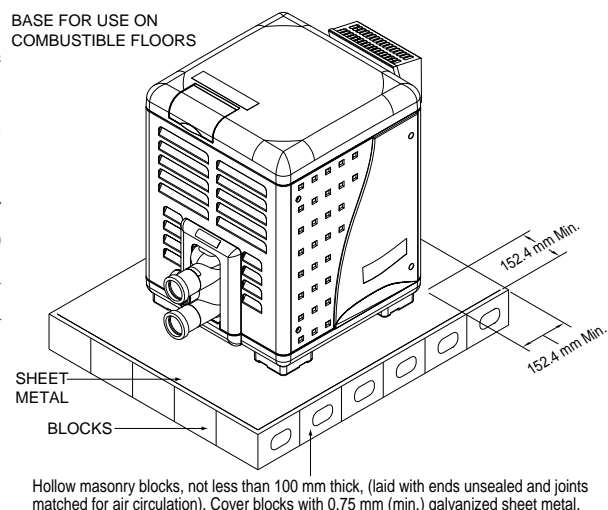

Figure 8.

For Heater mounting bolts and clamps, purchase separately Bolt Down Bracket Kit, Part No. 460738.

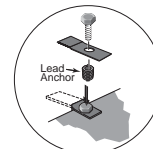

Figure 9.

HEATER CLEARANCES – OUTDOOR

IMPORTANT!

- In an outdoor installation it is important to ensure water is diverted from overhanging eaves with a proper gutter/drainage system. The heater must be set on a level foundation for proper drainage.
- This unit shall not be operated outdoors at temperatures below -7°C.

If the heater is located under a roof or deck overhang, there must be at least 1 meter (3 ft.) of clearance between the bottom of the overhang and the top of the heater exhaust vent, see Figure 10. If the heater is under a roof or deck overhang, the space around the heater must be open on three sides.

For minimum exhaust vent clearances for building openings, see below **Figure 11**.

Orient the heater for convenient access to the water connections and the gas and electrical connections.

Check local building codes for setback (property line) requirements.

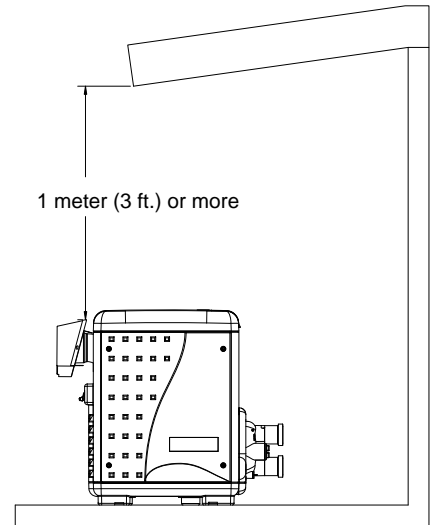

Figure 10.

⚠ CAUTION

If installing the heater next to or near an air conditioning unit or a heat pump, allow a minimum of 91.4 cm (36 in.) between the air conditioning unit and the heater.

OUTDOOR INSTALLATION VENTING GUIDELINES

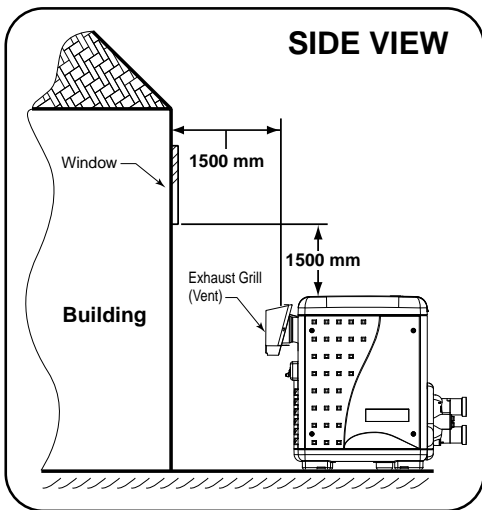
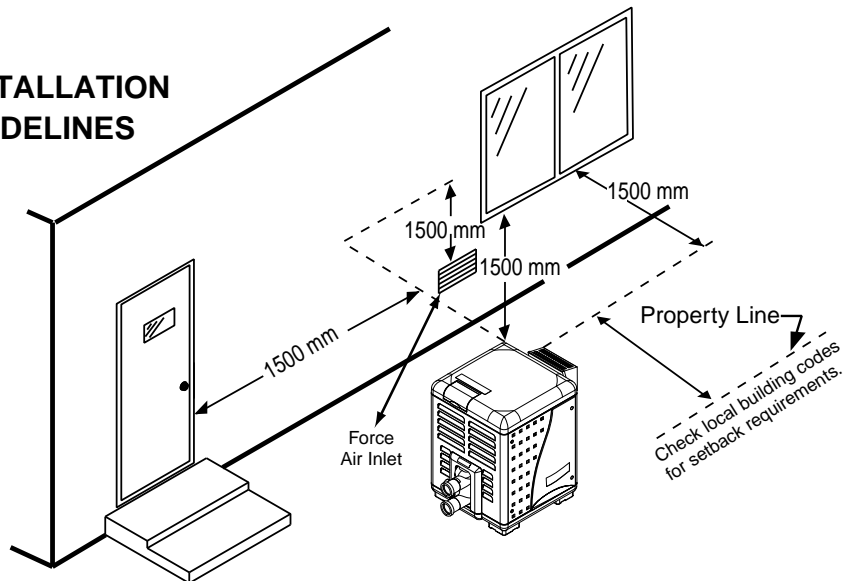

Figure 11.



Vent Termination:

- Must be installed at least 1500 mm away from the building wall openings, and at the following distances away from any door, window, or gravity air inlet.
- The heater must also have **no** obstructions above it.

⚠ WARNING

Risk of fire and explosion. Do not spray aerosols in the vicinity of the heater while it is in operation. Chemicals should not be stored near the heater installation. Combustion air can be contaminated by corrosive chemical fumes which can damage the heater and will void the warranty.

INDOOR VENTING — General Requirements

NOTE: REMOVE OR COVER “OUTDOOR ONLY” LABEL LOCATED ON HEATER OUTSIDE PANEL WITH “INDOOR INSTALLATION” LABEL (P/N 474275) INCLUDED IN METAL FLUE COLLAR KITS (P/N SF 43-11-06 AND SF 43-11-08).



If you are considering connecting this heater to a pre-existing vent system, make sure that the vent system meets the appropriate venting requirements as given in this manual on pages 17-25. If not, replace the vent system. **DO NOT** use a draft hood with this heater. The MasterTemp heaters are capable of a 270-degree discharge rotation and with a vent gas temperature less than 204° C (400° F). The total length of the horizontal run must not exceed the length that is listed in Table 7 on page 21.

HEATER CLEARANCES — General Requirements

INDOOR INSTALLATION AND OUTDOOR SHELTER

The following clearances must be maintained from the nearest walls: (See Figure 12 and Figure 12a)

TOP 15 cm. (6 in)

EXHAUST SIDE 15 cm (6 in.)

HEADER SIDE 15 cm (6 in.)

DOOR PANELS* 15 cm (6 in.)

Note (*) For service access it is advisable to allow for sufficient clearance on at least one door panel. The heater is designed for installation on combustible flooring. For installation on carpeting, the heater must be mounted on a metal or wood panel that extends at least three inches (10cm) beyond the base of the heater. If the heater is installed in a closet or alcove, the entire floor shall be covered by the panel. On an outdoor shelter installation, the exhaust discharges into a vent pipe. Orient the heater so that the vent pipe does not interfere with adjustment of the operating controls. The control panel located on the top panel can be rotated to any of the three sides of the heater for easy access. However, the control panel must not be located on the side where the vent is located.

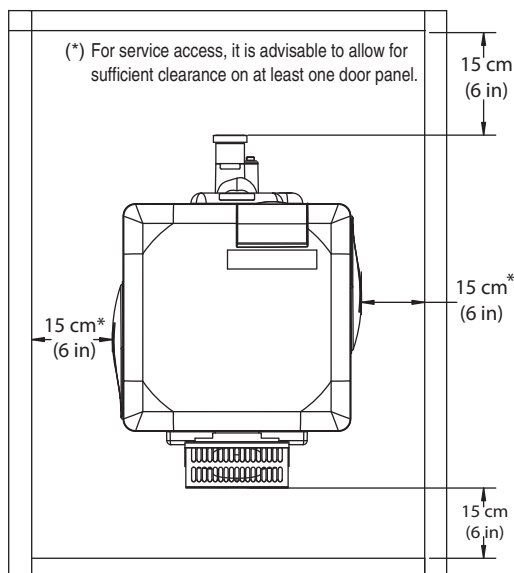

Figure 12

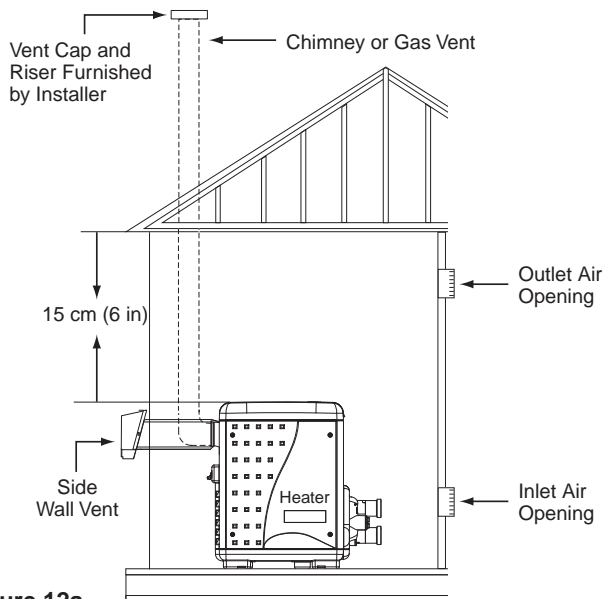

Figure 12a

OUTSIDE VENT COVER REMOVAL

The heater is supplied from the factory with a built-in stackless outside vent for outdoor installation. Remove the outside vent cover for outdoor shelter installation.

COMBUSTION AIR SUPPLY

Air Supply Requirements Guide for MasterTemp Heaters

For indoor installation, the heater location must provide sufficient air supply for proper combustion and ventilation of the surrounding area (in accordance with AS/NZS 5601.1).

The minimum requirements for the air supply specify that the room in which a heater is installed should be provided with two permanent air supply openings; one within 30 cm (12 in) of the ceiling, the other within 30 cm (12 in) of the floor for combustion air, in accordance with the AS/NZS 5601.1 as applicable, and any local codes that may apply. These openings shall directly, or through duct, connect to outdoor air.

Minimum Net Free Open Area for Each Opening* (Square Inches/Centimeters)				
Model	All Air From Inside Building		All Air From Outside Building	
	Combustion	Vent	Combustion	Vent
200	200 sq. in. 1290 sq. cm.	200 sq. in. 1290 sq. cm.	50 sq. in. 323 sq. cm.	50 sq. in. 323 sq. cm.
300	325 sq. in. 2097 sq. cm.	325 sq. in. 2097 sq. cm.	80 sq. in. 516 sq. cm.	80 sq. in. 516 sq. cm.
400	400 sq. in. 2580 sq. cm.	400 sq. in. 2580 sq. cm.	100 sq. in. 645 sq. cm.	100 sq. in. 645 sq. cm.

* Area indicated is for one of two openings; one at floor level and one at the ceiling.

Pentair Aquatic Systems does not recommend indoor installations that do not provide combustion air from outside the building. Table 4.

⚠ CAUTION
Chemicals should not be stored near the heater installation. Combustion air can be contaminated by corrosive chemical fumes which can void the warranty.

Corrosive Vapors and Possible Causes

Area	Likely Contaminants
Chlorinated swimming pools and spas	Pool or spa cleaning chemicals. Acids, such as hydrochloric or muriatic acid.
New construction and remodeling areas	Glues and cements, construction adhesives, paints, varnishes, and paint and varnish strippers. Waxes and cleaners containing calcium or sodium chloride.
Beauty parlors	Permanent wave solutions, bleaches, aerosol cans containing chlorocarbons or fluorocarbons.
Refrigeration plants or various industrial finishing and processing plants	Refrigerants, acids, glues and cements, construction adhesives.
Dry cleaning and laundry areas	Bleaches, detergents, or laundry soaps containing chlorine. Waxes and cleaners containing chlorine, calcium or sodium chloride.

Table 5.

VENT INSTALLATION – INDOOR INSTALLATION OR OUTDOOR SHELTER

Flueing must be in accordance with AS/NZS 5601.1

Always vent the heater to the outdoors, see Note*.

- Vent it vertically using double wall vent connector pipe.

Locate the heater so as to minimize the length of horizontal venting and the number of vent elbows required. Horizontal vent runs must slope to allow exhaust condensate to drain and it is recommended to have a condensate drain as described in the venting installation instructions.

NOTE *: Vent must be at least 2.4 m (8 ft) away from nearest vertical surface. Vents extending 1.5 m (5 ft) or more above the roof must be braced or guyed. Consult your local code officials for detailed information.

VERTICAL VENTING

(See Figures 12 and 14)

Vent the heater vertically in a system in accordance with AS/NZS 5601.1 and local codes. Double-wall vent connector is recommended; however single-wall pipe is allowed in some circumstances. Consult your local code official for detailed information. **Do not** use a draft hood with this heater.

To connect a double wall metal gas vent to the heater, order the appropriate Metal Flue Collar from the chart below:

- See Table 6 to determine allowable vent sizes for your heater.

Metal Flue Collar	Part No.
100 mm x 150 mm (4" x 6")	SF 43-11-06
100 mm x 200 mm (4" x 8")	SF 43-11-08

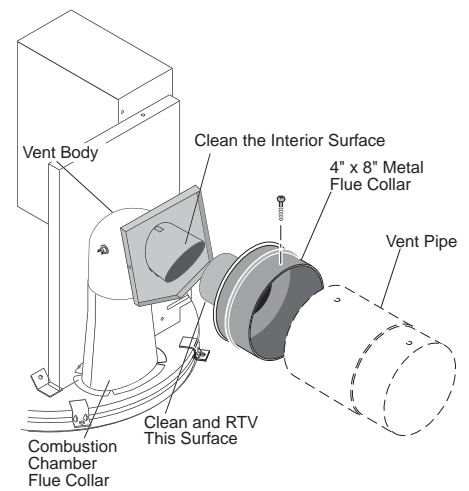

Figure 13.

NOTICE: Table 6 is for installations in which the total lateral vent length (that is, the horizontal distance from the flue collar to the main vertical portion of the vent) is less than half the total vent height (the vertical distance from the flue collar to the vent termination) and which have three or less elbows in the system. For vent lengths greater than 16 m (52.5 ft), only one elbow is allowed. See Table 6a below for details.

Read "VERTICAL VENTING" before using this table.

Table 6. – Permitted Minimum and Maximum Vent Heights By Size and Heater Model

Double-Wall Vent with Double-Wall Connector in Meters (Feet)			
Vent Size	Model 200 Height min./max.	Model 300 Height min./max.	Model 400 Height min./max.
150 mm (6 in.)	1.8 m (6 ft.) / 22 m (72 ft.)	Not Suitable	Not Suitable
200 mm (8 in.)	1.8 m (6 ft.) / 22 m (72 ft.)	1.8 m (6 ft.) / 22 m (72 ft.)	2.4 m (8 ft.) / 22 m (72 ft.)

Table 6a. – Maximum Number of Elbows per Vent Lengths

Maximum Number of Elbows per Vent Lengths		
Maximum Elbows Allowed	Maximum Total Vent Length	Maximum Horizontal Component (*)
3	2m (6.6 ft.)	0.67m (2.2 ft.)
	3m (9.8 ft.)	1m (3.3 ft.)
	4m (13.1 ft.)	1.33m (4.4 ft.)
	5m (16.4 ft.)	1.67m (5.5 ft.)
	6m (19.7 ft.)	2m (6.6 ft.)
2	7m (23 ft.)	2.33m (7.6 ft.)
	8m (26.2 ft.)	2.67m (8.8 ft.)
	9m (29.5 ft.)	3m (9.8 ft.)
	10m (32.8 ft.)	3.33m (10.9 ft.)
	11m (36.1 ft.)	3.67m (12 ft.)
	12m (39.4 ft.)	4m (13.1 ft.)
	13m (42.6 ft.)	4.33m (14.2 ft.)
	14m (45.9 ft.)	4.67m (15.3 ft ft.)
1	15m (49.2 ft.)	5m (16.4 ft.)
	16m (52.5 ft.)	5.33m (17.5 ft.)
	17m (55.8 ft.)	5.67m (18.6 ft.)
	18m (59 ft.)	6m (19.7 ft.)
	19m (62.3 ft.)	6.33m (20.8 ft.)
	20m (65.6 ft.)	6.67m (21.9 ft.)
	21m (68.9 ft.)	7m (23 ft.)
	22m (72.2 ft.)	7.33m (24 ft.)

(*) The maximum horizontal component of the flue length is 1/3 of the total length.

2. Install the metal Flue Collar in the Vent Body of the heater (located under the outside vent cover). Fasten the metal Flue Collar to the Vent Body with two #10 sheet metal screws. Use high temperature silicone RTV to seal the Flue Collar to the Vent Body. Before connecting the metal Flue Collar to the Vent Body, wet a clean cloth or paper towel with isopropyl alcohol (rubbing alcohol) and vigorously wipe the socket of the Vent Body. Immediately wipe the cleaned surfaces dry with a clean cloth or paper towel. Repeat for the exterior of the 100 mm (4") end of the metal Flue Collar. Attach the metal Flue Collar to the Vent Body using the RTV supplied with the kit, following the vent manufacturer's instructions (included with kit).
3. Attach the vent pipe to the metal Flue Collar with sheet-metal screws.

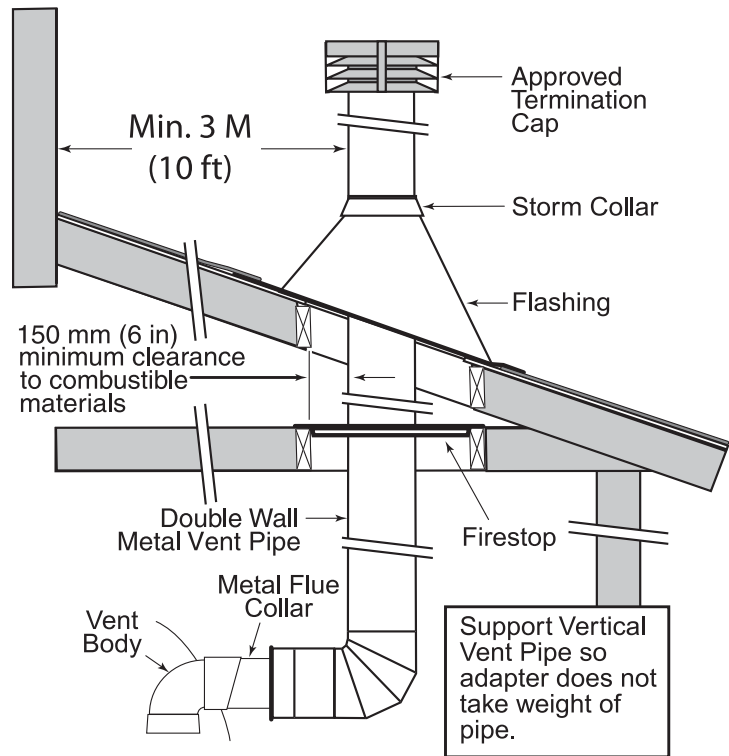

⚠ WARNING

Risk of fire or asphyxiation if vent is not assembled according to manufacturer's instructions or if vent parts from different manufacturers are mixed. Vent parts from different manufacturers ARE NOT interchangeable. Mixing parts from more than one manufacturer may cause leaks or damage to vent. When assembling a vent, pick one manufacturer and be sure that all vent parts come from that manufacturer and are specified by the manufacturer for your system. Follow manufacturer's instructions, local code requirements and AS/NZS 5601.1 standards carefully during assembly and installation.

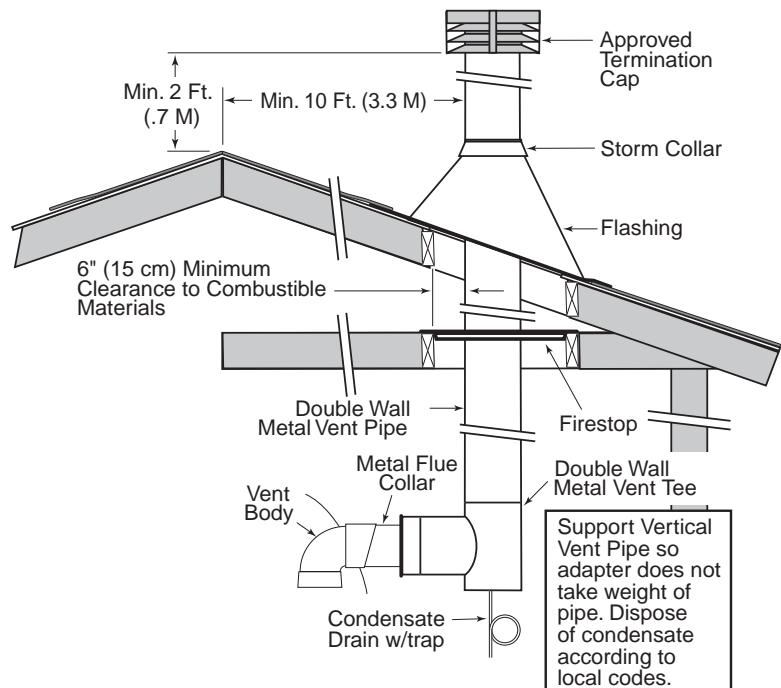

Figure 14. – Typical Metal Vent Pipe Installation (Vertical Venting)

4. Install vent pipe so that it can expand and contract freely as the temperature changes. Support the vent pipe according to applicable codes and the vent manufacturer's instructions. Pipe support must allow the vent pipe free movement out and back, from side to side, or up and down as necessary, without putting a strain on the heater or vent body. Slope horizontal pipe down to condensate trap at least 2 cm per meter (1/4 in per foot). Install approved condensate drains at low points where condensate might collect. Plumb condensate drains to a drain through hard piping or high temperature tubing such as silicone rubber or EPDM rubber – do not use vinyl or other low temperature tubing. Follow drain manufacturer's installation instructions.

5. Use approved fire stop for floor and ceiling penetrations. Use approved thimble for wall penetrations. Use a approved roof flashing, roof jack, or roof thimble for all roof penetrations. Do not fill the space around the vent (that is, the clear air space in the thimble or fire stop) with insulation. The roof opening must be located so that the vent is vertical.
6. **Do not run the heater vent into a common vent with any other appliance.**

⚠ WARNING

Fire Hazard. Do not vent the heater directly into a masonry chimney. Installation into a masonry chimney must use a chimney liner which must meet AS/NZS 5601.1 standards and all local code requirements.

⚠ WARNING

Risk of fire, carbon monoxide poisoning, or asphyxiation. It is recommended to use a CO Monitor and Fire Alarm in rooms that contain gas fired appliances.

NOTE

After installation, installer must check for correct and safe operation of the heater.

HORIZONTAL OR VERTICAL VENTING - USING SINGLE-WALL STAINLESS GAS VENT (See Figures 15, 16 & 17)

Vent the heater either horizontally or vertically using an optional vent adapter of the 150 mm (6 in) special gas approved **stainless steel** vent pipes. Installation must be in accordance with all local codes and ordinances/or the latest edition of the *AS/NZS 5601.1* standards and/or local codes. The heater, when installed, must be electrically grounded and bonded in accordance with local codes. Do not use a draft hood with this heater. Install the vent according to the vent manufacturer’s detailed instructions. **Note:** Keep a 150 cm (6 in) minimum clearance between the vent pipe and combustible surfaces. Follow the vent manufacturer’s instructions and code requirements. Do not place any insulating materials around the vent or inside the required clear air space surrounding the vent. See **Table 7** for maximum permissible vent lengths. Table 7.

NOTE

The allowable vent runs for each vent pipe diameter are different and can not be exceeded. Each 90-degree elbow reduces the maximum horizontal vent run by 3.6 m (12 feet) and each 45-degree elbow in the vent run reduces the maximum vent run by 1.8 m (6 feet). See the Table 7 for the maximum vent lengths using 90° elbows.

NOTE

It is recommended that vent runs over 5.4 m (18 feet) may need to be insulated to reduce condensation related problems and/or the use of a condensate trap in the vent run close to the heater may be necessary in certain installations such as cold climates. Horizontal vents 1 m (3 feet) or less in length do not require a condensate tee. The heater is suitable for through-the-wall venting.

150 mm (6 in.) Special Gas Vent (Vertical or Horizontal)*	
No. of 90° Elbows	Maximum Length in Meters (feet)
0	11.6 m (38 ft.)
1	8 m (26 ft.)

*Minimum vent length is 0.34M (1 ft.) or in accordance with vent manufacturer’s instruction, and local and national codes. Horizontal vents 1 m (3 ft.) or less in length do not require a condensate tee, but must slope down toward the outlet at 2 cm to the meter (1/4 in / ft.) to allow condensate to drain.

Flue gases may escape into the dwelling with any cracks or loose joints in the vent pipe, or improper vent installation. The vent pipe must be of a sealed-seam construction and for operating temperatures less than 204° C (400°F). Vent pipe construction will be of AS/NZS 5601.1 approved non-corrosive material, such as stainless steel. A condensate trap may be needed. The use of “Approved” thimbles, roof jacks and/or side vent terminals are required; and the proper clearances to combustible materials must be maintained in accordance with type of vent pipe employed—in the absence of a clearance recommendation by the vent pipe manufacturer, the requirements of the Uniform Mechanical Code should be met. **The ventilation air requirements for the MasterTemp heater can be found on page 18.** It is recommended that vent runs over 5.4 M (18 ft) may need to be insulated to reduce condensation related problems and/or the use of a condensate trap in the vent run close to the heater may be necessary in certain installations such as cold climates. Horizontal vents 1 M (3 ft) or less in length do not require a condensate tee. The MasterTemp heater is suitable for through-the-wall venting.

NOTE

After installation, installer must check for correct and safe operation of the heater.

CONNECTING SINGLE-WALL STAINLESS STEEL VENT TO THE HEATER

Metallic:

1. Order an optional appliance adapter kit, (*Pentair offers optional appliance adapter kits, call our Customer Service dept.*):
- Part No. 77707-0086 for Saf-T Vent® or Saf-T Vent® CI. - Part No. 77707-0087 for Z-Vent.
2. Remove the outside vent cover.
3. Install the Appliance Adapter in the Vent Body of the heater (located under the outside Vent Cover). Before connecting the Appliance Adapter to the Vent Body, wet a clean cloth or paper towel with isopropyl alcohol (rubbing alcohol) and vigorously wipe the socket of the Vent Body. Immediately wipe the cleaned surfaces dry with a clean cloth or paper towel. Repeat for the exterior of the heater end of the Appliance Adapter. Attach the appliance adapter to the vent body using the adhesive specified by the vent manufacturer, following the vent manufacturer's instructions.

⚠ WARNING

Risk of carbon monoxide poisoning if adapter is improperly attached. Mechanical connections (such as screws) can cause cracking and leaks in the adapter. Do **NOT** drill holes or use screws to connect the appliance adapter to the heater vent body. Attach with manufacturer's specified adhesive.

⚠ WARNING

Risk of fire or asphyxiation if vent is not assembled according to manufacturer's instructions or if vent parts from different manufacturers are mixed. Vent parts from different manufacturers ARE NOT interchangeable. Mixing parts from more than one manufacturer may cause leaks or damage to vent. When installing a vent, pick one manufacturer and be sure that all vent parts come from that manufacturer and are specified by the manufacturer for your system. Follow manufacturer's instructions and local and AS/NZS 5601.1 requirements carefully during assembly and installation.

4. Install vent pipe so that it can expand and contract freely as the temperature changes. Support the vent pipe according to applicable codes and vent manufacturer's instructions. Pipe support must allow the vent pipe free movement out and back, from side to side, or up and down as necessary, without putting a strain on the heater or vent body. It is recommended to slope the horizontal pipe down to condensate trap at least 2cm/M (1/4 in per foot). Install "Approved" condensate drains at low points where condensate might collect. Plumb condensate drains to a drain through hard piping or high-temperature tubing such as silicone rubber or EPDM rubber – do not use vinyl or other low temperature tubing. Follow drain manufacturer's installation instructions.
5. Use an "Approved" firestop for floor and ceiling penetrations. Use an "Approved" thimble for wall penetrations. Use an "Approved" roof flashing, roof jack, or roof thimble for all roof penetrations. Do not fill the space around the vent (that is, the clear air space in the thimble or firestop) with insulation. The roof opening must be located so that the vent is vertical.

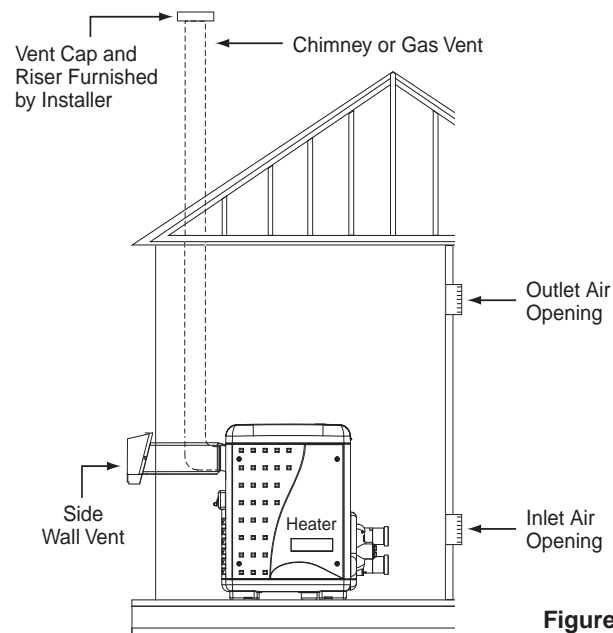

Figure 15.

6. **Vent Termination – Vertical** (See Figures 14, 15 and 16), for height of vent termination above the roof. Use an "Approved" vent terminal specified by local and national codes and your manufacturer's instructions. A roof termination must be vertical.
7. Make sure entire installation is sealed according to approved standard.

8. Vent Termination – Horizontal

The terminal must be located (See Figure 17):

- at least 76 mm (3 in) and at most 304 mm (12 in) out from the wall (see Figure 18), following the vent manufacturer's instructions
- at least 304 mm (12 in) above finished grade or the normally expected snow accumulation level, whichever is higher
- at least 1.2 M (4 ft) below or horizontally from, or 0.3 M (1 ft) above, any doors or windows or gravity air inlet to a building
- at least 0.9 M (3 ft) above any forced air inlet located within 3 M (10 ft)
- at least 1.2 M (4 ft) horizontally from electric meters, gas meters, regulators and relief equipment
- at least 2.1M (7 ft) above grade adjacent to walkways or similar traffic areas.

continue with step 9 on page 24.

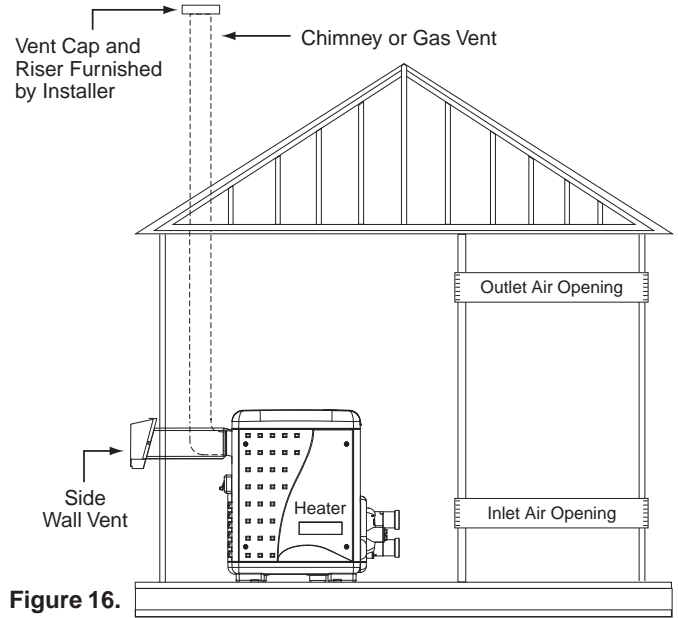

Figure 16.

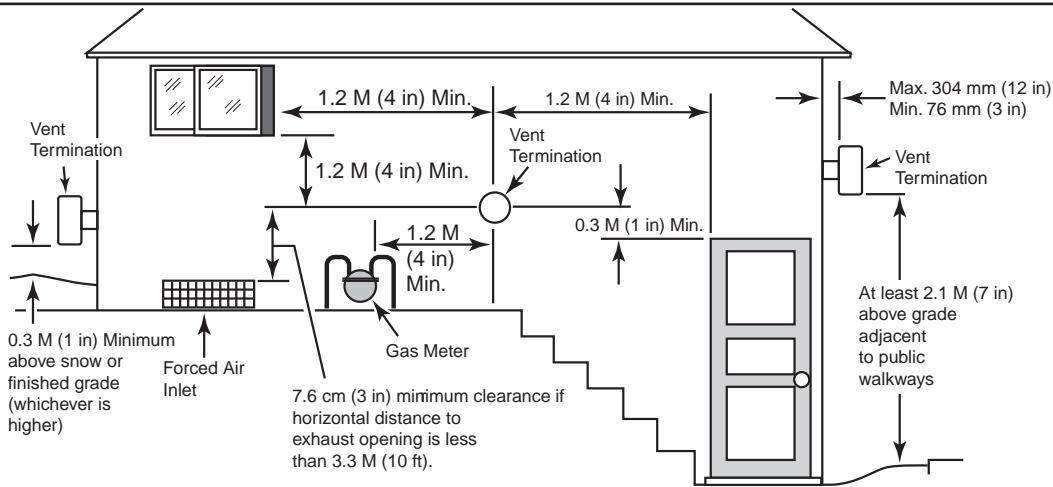
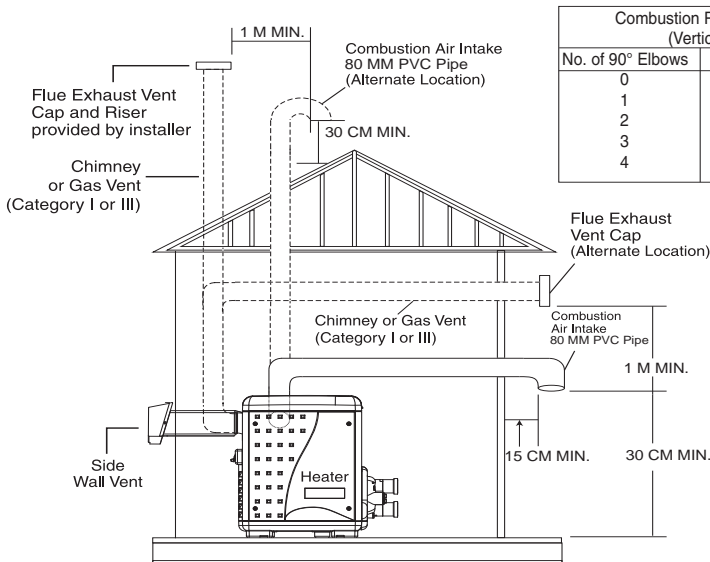

Figure 17.

Direct Air Intake Duct with 80 mm PVC Pipe (Indoor Installation)

For indoor heater installations where combustion air supply might be insufficient, the MasterTemp® Heater is certified for a direct air intake duct using 80 mm PVC pipe. If outside air is drawn through 80 mm PVC duct directly into the heater, PVC pipe can be installed in accordance with the following requirements: The air intake opening MUST be installed at least 30 cm above the roof line or normal snow levels for free air flow. The Category I or III exhaust vent termination cap must have at least 1 m minimum vertical clearance from air intake duct. (See following diagram).



WARNING!
DO NOT USE PVC PIPE FOR FLUE EXHAUST VENT. FLUE EXHAUST VENT TEMPERATURES CAN BE IN EXCESS OF 250°C. FLUE EXHAUST VENT **MUST BE** CATEGORY I or CATEGORY III METAL VENT.

NOTE
Each 90-degree elbow reduces the maximum horizontal PVC air intake duct run by 4 m and each 45-degree elbow in the PVC air intake duct run reduces the maximum run by 2 m. See the Table above for the maximum lengths using 90-degree elbows.

9. Vent Termination – Horizontal (Continued)

The terminal must be located (See Figure 17):

- at least 3.3M (10 ft) from any opening into a building
- at least 0.3 M (12 in) above finished grade or the normally expected snow accumulation level, whichever is higher
- at least 1.2 M (4 ft) horizontally from electric meters, gas meters, regulators and relief equipment
- at least 2.1 M (7 ft) above grade adjacent to walkways or similar traffic areas

Allow at least 1 M (3 ft) vertical clearance over vent termination when terminating under an overhang or deck.

Avoid corners or alcoves where snow or wind could have an effect. Exhaust may affect shrubbery and some building materials. Keep shrubbery away from termination. To prevent staining or deterioration, sealing or shielding exposed surfaces may be required.

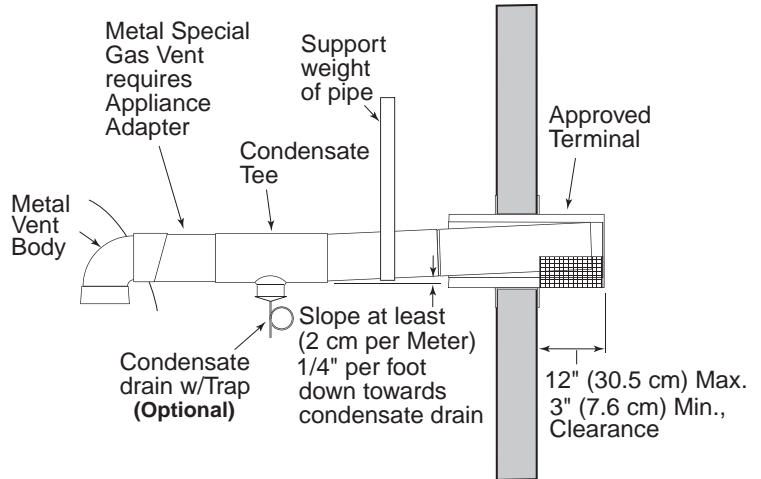

Figure 18.

⚠ WARNING

Fire Hazard. Do not run the heater vent into a common vent with any other appliance. Do not run the Special Gas Vent into, through, or within any active vent such as a factory built or masonry chimney.

NOTE: After installation, installer must check for correct and safe operation of the heater.

HORIZONTAL OR VERTICAL VENTING FLEXIBLE DUCT (FLEX-VENT)

(See Figures 15, 16, 17 & 19)

NOTE: THE ALLOWABLE VENT RUNS FOR EACH VENT PIPE DIAMETER ARE DIFFERENT AND CAN NOT BE EXCEEDED.

It is recommended that vent runs over 5.4 m (18 ft) may need to be insulated to reduce condensation related problems and/or the use of a condensate trap in the vent run close to the heater may be necessary in certain installations such as cold climates. Horizontal vents 1 m (3 feet) or less in length do not require a condensate tee. The MasterTemp heater is suitable for through-the-wall venting. See Table 8 for maximum permissible Flexible Vent lengths.

⚠ CAUTION

Do **NOT** combine exhaust vent pipes to a common exhaust vent in multiple unit installations. Run separate vent pipes.

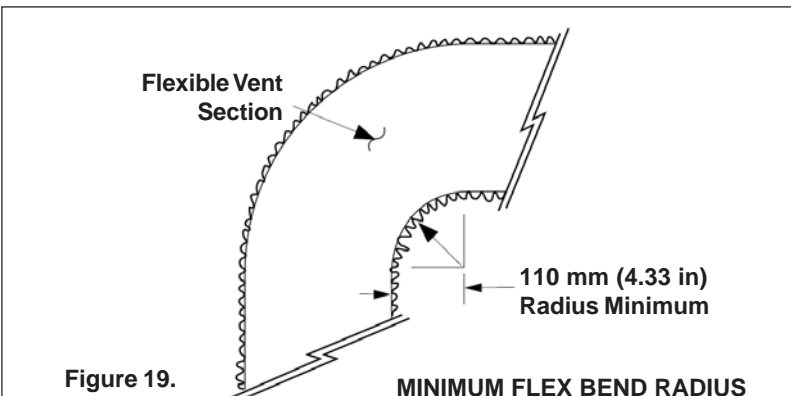

Figure 19.

150 mm (6 in.) Flex-Vent (Vertical or Horizontal)*	
No. of 90° Bends	Maximum Length in Feet (M)
0	11.6 m (38 ft.)
1	8 m (26 ft.)

*Minimum vent length is 0.34M (1 ft.) or in accordance with vent manufacturer's instruction, and local and national codes. Horizontal vents 1 m (3 in) or less in length do not require a condensate tee, but must slope down toward the outlet at 2 cm to the meter (1/4 in / ft.) to allow condensate to drain.
 ** Radius minimum to be 110 mm (4.33 in) as shown in Figure 19.

Table 8.

NOTE: KEEP A 150 CM (6 IN) MINIMUM CLEARANCE BETWEEN THE VENT PIPE AND COMBUSTIBLE SURFACES. FOLLOW THE VENT MANUFACTURER'S INSTRUCTIONS AND CODE REQUIREMENTS.

Each 90° bend reduces the maximum horizontal vent run by 3.6 m (12 feet) and each 45° bend in the vent run reduces the maximum vent run by 1.8 m (6 feet). See Table 8 for the maximum vent length using one 90° bend.

NOTE

After installation, installer must check for correct and safe operation of the heater.

Corrosive Vapors and Possible Causes

Area	Likely Contaminants
Chlorinated swimming pools and spas	Pool or spa cleaning chemicals. Acids, such as hydrochloric or muriatic acid.
New construction and remodeling areas	Glues and cements, construction adhesives, paints, varnishes, and paint and varnish strippers. Waxes and cleaners containing calcium or sodium chloride.
Beauty parlors	Permanent wave solutions, bleaches, aerosol cans containing chlorocarbons or fluorocarbons.
Refrigeration plants or various industrial finishing and processing plants	Refrigerants, acids, glues and cements, construction adhesives.
Dry cleaning and laundry areas	Bleaches, detergents, or laundry soaps containing chlorine. Waxes and cleaners containing chlorine, calcium or sodium chloride.

Figure 20.

CONTROL PANEL INDEXING

On an outdoor shelter installation, the exhaust discharges into a vent pipe. Orient the heater so that the vent pipe does not interfere with adjustment of the operating controls. The control panel located on the top panel can be rotated to any of the three sides of the heater for easy access, see Figure 20.

1. Remove the bolts from the door panels. Remove both door access panels.
2. Remove the four corner screws that secure the top panel. Lift the top panel upward to remove the top panel.
3. Rotate the top panel to the desired position located at 90° angles. *Note that the control panel must **NOT** be located on the side where the vent is located.*
4. Replace the top panel down onto the side panels. Be sure that there are no wires caught under the panel.
5. Secure the top panel using the four corner screws.
6. Reattach the door access panels.

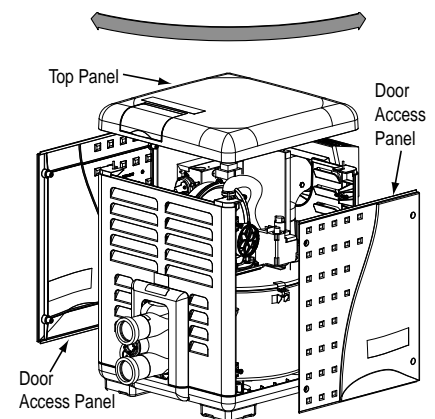

For Heater mounting bolts and clamps, purchase separately Bolt Down Bracket Kit, Part No. 460738.

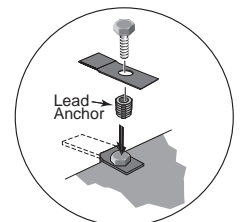

Figure 21.

FINAL INSTALLATION CHECK

After installation, the installer **MUST test and check that the heater is operating and functioning properly.** Some building codes require that the heater be anchored to the equipment pad or platform to withstand high wind pressures created during hurricanes. A Bolt Down Bracket Kit, P/N 460738, is available with anchor clamps designed to hold the unit to the equipment pad in high wind conditions, see Figure 21. Installation of the anchor clamps are recommended in all installations.

ELECTRICAL CONNECTIONS

Electrical Rating 50 Hz 240 Volts AC, single phase; 12 AMP inrush, 5 AMP steady state.

The heater is supplied with a 240 VAC, 10 AMP, 50 Hz power cord (AS/NZS 3112) approved for outdoor use. The power cord wire is 3 x 16 AWG (3 x 10 mm²).

⚠ CAUTION

This heater is designed to operate at 230 - 240 VAC. It is not recommended to be connected to OR operate on a 208 VAC.

NOTE

- If any of the original wiring supplied with this heater must be replaced, installer must supply (No. 18 AWG, 600V, 105° C. U.L. approved AWM low energy stranded) copper wire or it's equivalent.

Please read the boxes headed “IMPORTANT! READ ME FIRST!” on pages 35 and 39 before proceeding.

1. All wiring must be in accordance with all applicable codes and **must be wired by a licensed electrician to AS3000 Wiring rules.**
2. The heater, when installed, must be electrically grounded and bonded in accordance with local codes or, in the absence of local codes, with the National Electrical Standards. A bonding lug is provided on the outside of the panel under the vent for this purpose.
3. Electrical power circuits to the pool heater must follow local codes and National Electrical Standards. **Note: The heater will not ignite if the active and neutral wires are reversed. Check the powerpoint with an approved device. If required, have an electrician correct the wiring.**
4. All wiring between the heater and devices not attached to it, or between separate devices which are installed in the field, must be “Type T” wire rated for 35°C rise.
5. **The filter pump should run continuously when the heater is on, and for at least 15 minutes after the heater turns off.** Any switches in the pump circuit (including circuit breakers) that can disconnect the pump must also disconnect the heater.
6. Do not wire single-pole switches, including protective devices, into a grounded line. The heater is not sensitive to polarity.

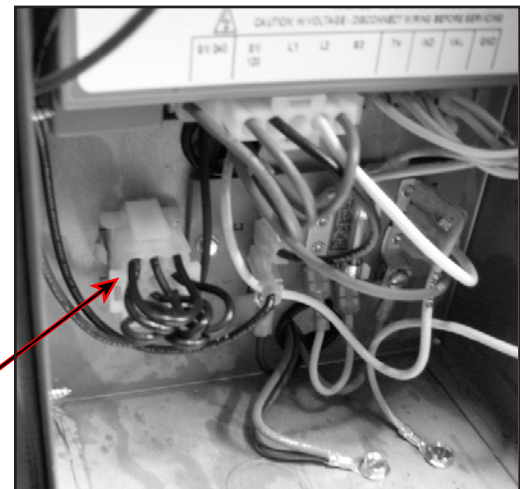

Figure 22.

Use the provided waterproof wire nuts when connecting the power supply.

A time clock controlling the filter pump should have a low-voltage Fireman's Switch that switches off the heater at least 15 minutes before shutting off the pump.

Note: If the filter pump is turned OFF while the heater is running, the residual heat will likely cause the inlet High Limit switch to trip. A controller with pump run in timer is recommended.

CONNECTION OF FIREMAN'S SWITCH OR REMOTE CONTACT

⚠ CAUTION

If, while there is line voltage connected to the heater, you touch either line voltage terminal with any 24VAC wire that is connected to the control board (including the Fireman's Switch jumper), you will immediately destroy the control board and void the warranty.

REMOTE CONTROL CONNECTIONS

1. Switch off power to heater at main circuit breaker panel.
2. Unbolt and remove the access door panels.
3. Open control box cover (see Figure 23).
- 4a. *To connect a 2-Wire Control* (such as Pentair's IntelliTouch™ or EasyTouch™ control systems) *or a timer*:
 - Remove the factory installed jumper from the Fireman's Switch terminals.
 - Connect wires between the Fireman's Switch terminals on the heater and the relay. Connect wires from the controller or timer to the Fireman's Switch. Controller, timer or relay should be sized to handle 24VAC at 0.5 Amp (because it will be completing the 24VAC control board circuit on the heater as shown in Figure 24). DO NOT apply line voltage to the Fireman's Switch terminals. Use 18 gauge wire with a minimum 1.2 mm (3/64 in.) thick insulation rated for a temperature rise of at least 105° C.
 - Knock-outs are provided to route the wires through the bottom of the control box and past the junction box.
- 4b. *To connect a 3-Wire Control*:
 - Connect wires between the control board terminals on the heater and the external relays, as shown in Figure 25 on page 28. Use at least 2 relays per heater, to allow for an "OFF setting" on each heater mode. Select relays that can handle logic level switching. DO NOT apply line voltage to control board terminals.
 - Move jumper (as shown in Figure 25 on page 28) to enable external control and to disable the heater membrane pad's "Pool ON" and "Spa ON" buttons (the "OFF" key on the membrane pad remains functional).
 - Knock-outs are provided to route the wires through the bottom and the top of the control box and past the junction box.
5. Close control box cover.
6. Re-install the access door panels.

To control heaters that are operated in parallel, connect wiring at same locations on heater as 2-Wire or 3-Wire Control. It is imperative that each control circuit is isolated from the other control circuits, to avoid that current will flow from one heater to another through the control circuits.

NOTICE: The fuse for the Fireman's Switch is a 1.25 Amp 31.75 mm x 6.35 mm fast blow fuse, which is commonly available.

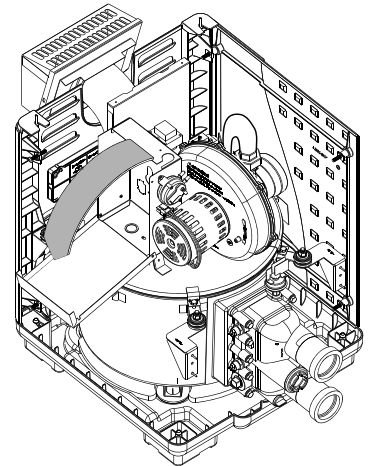

Figure 23.

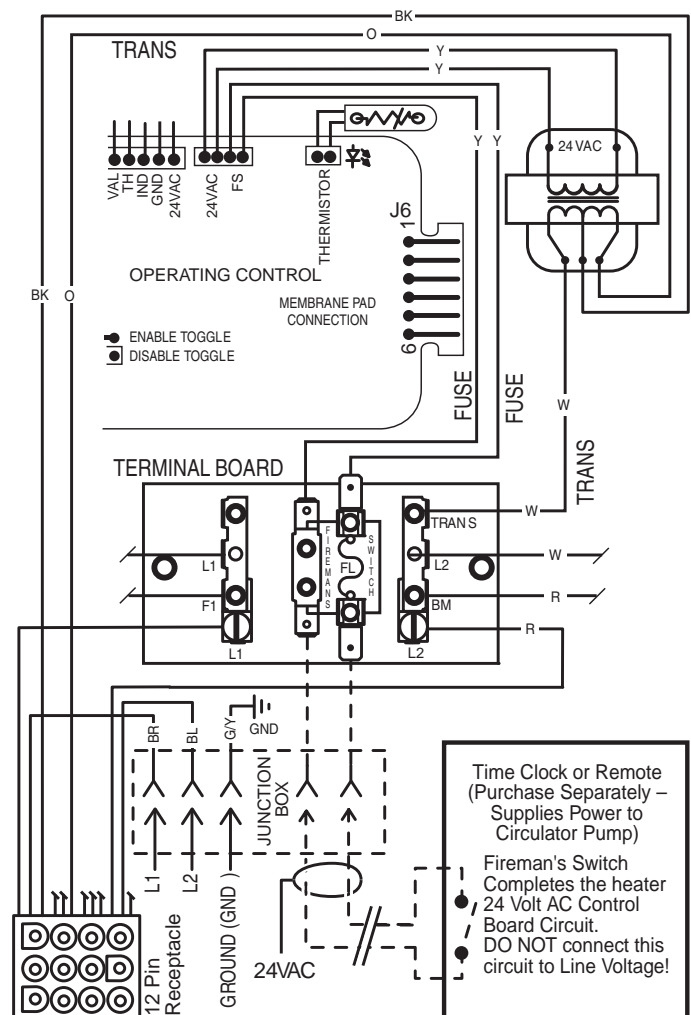

Figure 24.

MASTERTEMP WIRING DIAGRAM

(3-WIRE SYSTEM)

CONNECTION DIAGRAM

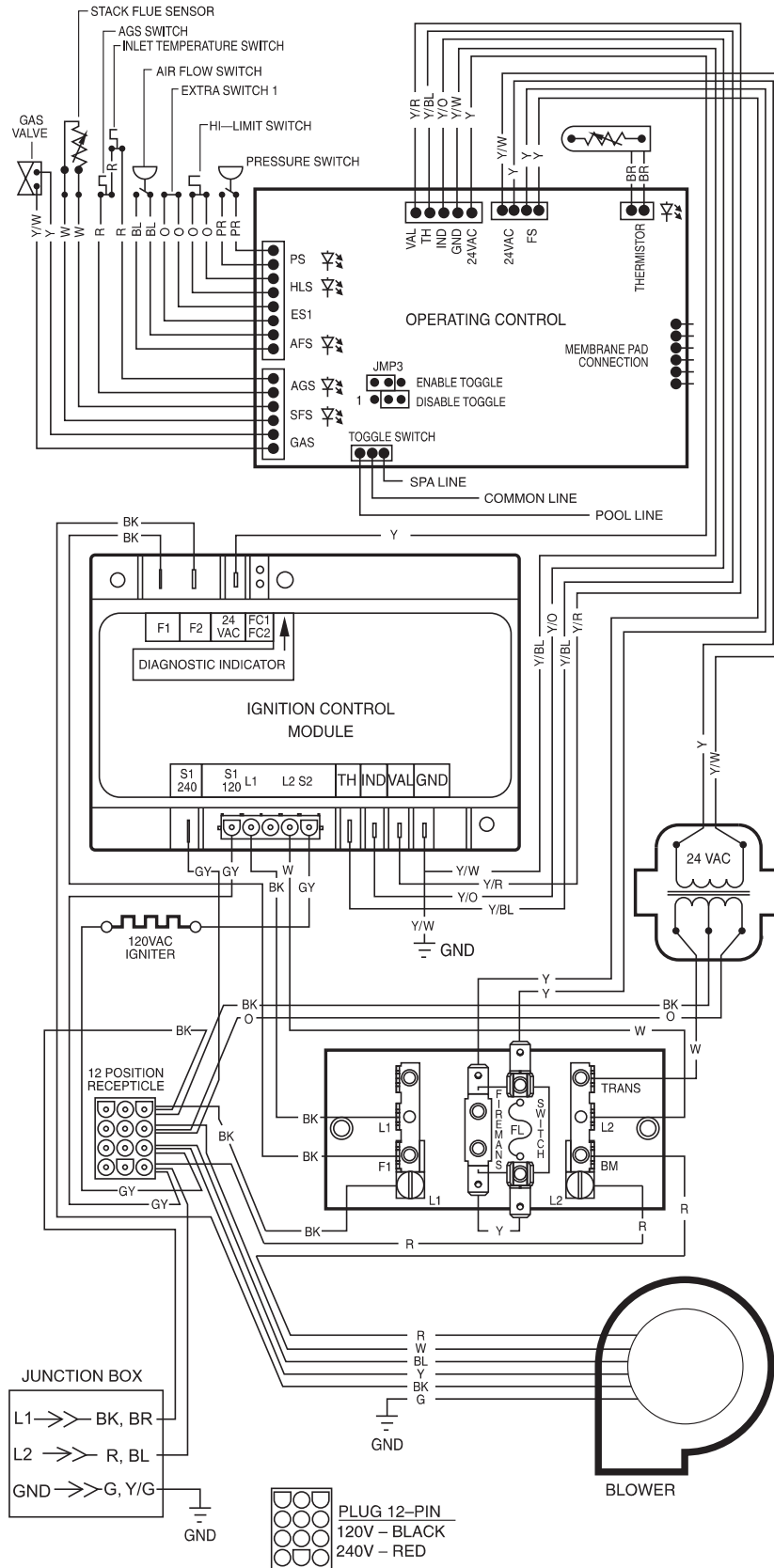
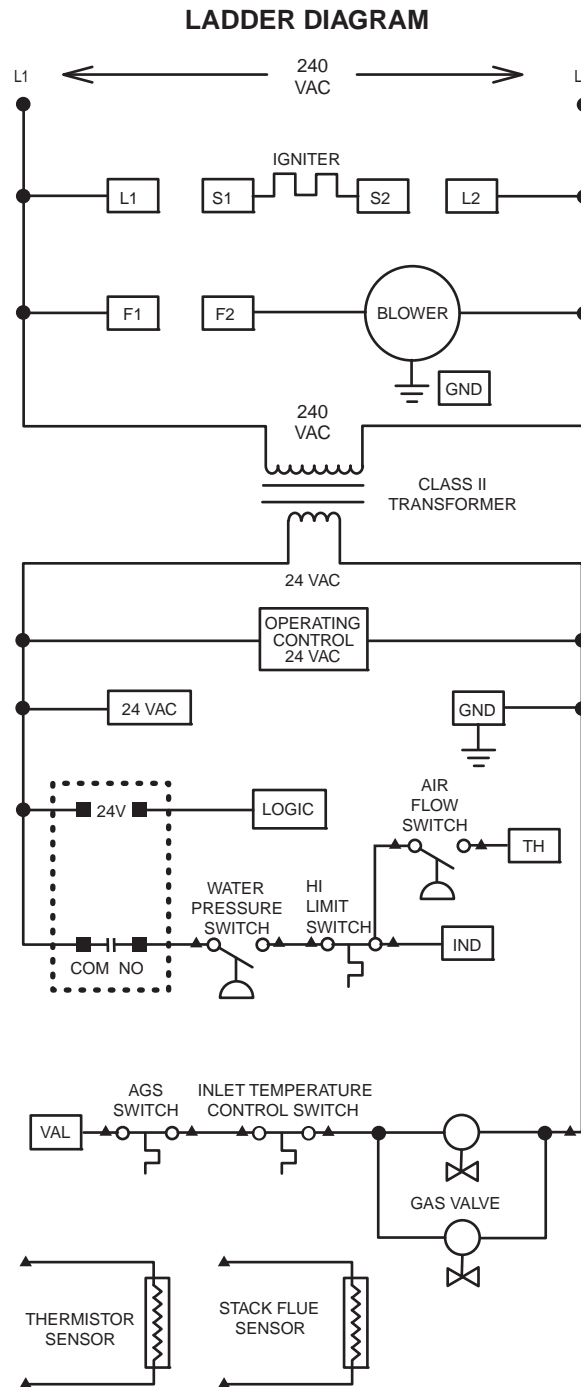

Figure 25.

MASTERTEMP ELECTRICAL SCHEMATIC LADDER DIAGRAM



NOTES:

- 1.) L1 L2 F1 F2 S1 24 VAC
S2 GND IND VAL AND TH
ARE CONNECTED ON THE IGNITION MODULE.
- 2.) ▲ PIN AND SOCKET CONNECTOR.
- 3.) IF ANY OF THE ORIGINAL WIRES AS SUPPLIED WITH THE APPLIANCE MUST BE REPLACED, THEY MUST BE REPLACED WITH TYPE 105° C OR ITS EQUIVALENT.

Figure 26.



Operation Instructions

BASIC SYSTEM OPERATION

Start pump, make sure the pump is running and is primed, to close the water pressure switch and supply power to heater. Be sure the pool and/or spa is properly filled with water. Follow the Lighting/Operating instructions below.

MASTERTEMP HSI ELECTRONIC IGNITION LIGHTING/OPERATION

FOR YOUR SAFETY: READ BEFORE LIGHTING

 WARNING	
	If you do not follow these instructions exactly, a fire or explosion may result causing property damage, personal injury or loss of life.
	Do not attempt to light the heater if you suspect a gas leak. Lighting the heater can result in a fire or explosion which can cause personal injury, death, and property damage.

START-UP AND OPERATION

START-UP AND SHUTDOWN INSTRUCTIONS ARE ON THE LABEL ATTACHED TO THE COVER OF THE APPLIANCE CONTROL BOX.

BEFORE START-UP

- A. This appliance does not have a pilot. It is equipped with an ignition device which automatically lights the burners. Do not try to light the burners by hand.
- B. **BEFORE OPERATING**, smell all around the appliance area for gas. Be sure to smell next to the floor because some gas is heavier than air and will settle on the floor.
- WHAT TO DO IF YOU SMELL GAS**
 - Do not try to light any appliance.
 - Do not touch any electrical switch; do not use any phone in your building.
 - Immediately call your gas supplier from a neighbor's phone. Follow the gas supplier's instructions.
 - If you cannot reach your gas supplier, call the Fire Department.
- C. Use only your hand to turn the gas control on or off. Never use tools. If you cannot change the ON/OFF setting by hand, don't try to repair it, call a qualified service technician. Forced or attempted repair may result in a fire or explosion.
- D. Do not use this heater if any part has been under water. Immediately call a qualified service technician to inspect the heater and to replace any part of the control system and any gas control which has been under water.
- E. Do not operate the pool heater unless the pool or spa is properly filled with water.
- F. Before operating the appliance for the first time or after it has been off for an extended time, perform the following checklist:
 1. Remove debris or other articles from inside the heater and the area around the heater and its exhaust vent. Make sure the ventilation openings are clear of debris or obstruction. For installations in an enclosed space, make sure openings for combustion and ventilation air are unobstructed.
 2. Keep heater area clear and free from combustibles, flammable liquids and chemicals.
 3. Check that all water connections are tight.
 4. Water must be flowing through the heater during operation. Make sure that pool/spa is filled with water and have pump operating. Check that water flow is unobstructed from the appliance. When operating for the first time or after an extended shut-down, run filter pump for several minutes to clear all air from the system.

OPERATING INSTRUCTIONS

1. **STOP!** Read the safety information on (page 30).
2. Set both pool and spa thermostats to the lowest settings.
3. Turn off all electric power to the appliance.
4. This appliance does not have a pilot. It is equipped with an ignition device which automatically lights the burner. Do not try to light the burner by hand.
5. Turn **off** the outside external manual shut-off gas valve, see Figure 27.
6. Wait five (5) minutes to clear out any gas. If you then smell gas, **STOP!** Follow “B” in the “Before Start-up” instructions (page 30). If you don’t smell gas, go to the next step.
7. Turn **on** the outside external manual shut-off gas valve, see Figure 27.
8. Set 3-way valves on inlet and outlet to pool or spa, as appropriate.
9. Turn on all electric power to the appliance.
10. Press either the POOL ON or SPA ON button switch on the operating control.
11. Set the thermostat to desired setting (**NOTICE:** Setpoint must be above actual water temperature or burner will not fire). See “OPERATING the CONTROL PANEL”.
12. The blower should come on immediately, and after about 20 seconds, the burner should fire. When operating for the first time, the burner may not fire on the first try because of air in the gas line. If it does not fire at first, push the OFF switch, wait five minutes, and again push the POOL or SPA ON switch. The burner should fire after about 20 seconds. You may have to repeat this until all of the air has cleared the gas line.
13. The burner should fire until the pool/spa temperature reaches the desired temperature set on the thermostat. The blower will continue to run for about 45 seconds after the burner shuts off. If any of the safety interlocks should open during burner operation, the burner shuts off immediately, but the blower continues to run for about 45 seconds. Should overheating occur or the gas supply fail to shut off, turn off the manual gas control valve to the appliance.
14. If the appliance will not operate, follow the instructions below “TO TURN OFF GAS TO THE APPLIANCE”, and call your service technician or gas supplier.
15. If the electrical power is lost while the heater is running, the heater will retain all program settings and the unit will come back to it’s original mode and settings once the power is restored.

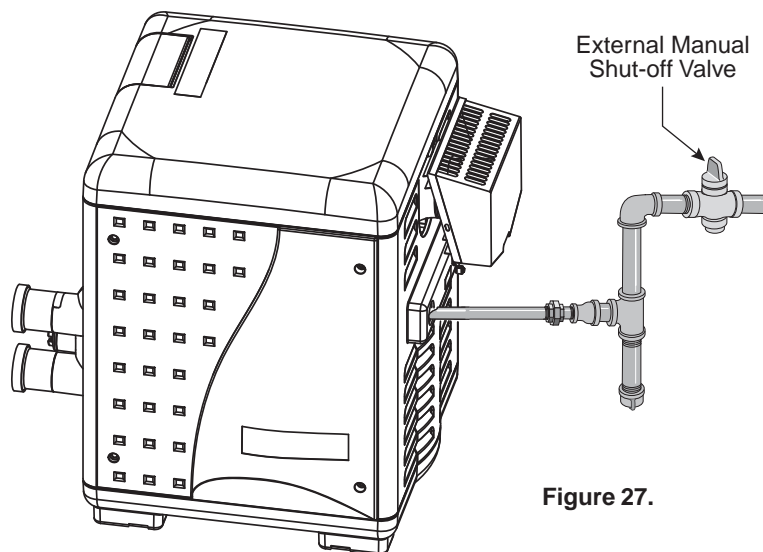

Figure 27.

TO TURN OFF GAS TO APPLIANCE

1. Press the OFF button on operating control.
2. Switch off all electric power to the unit.
3. Turn **off** the outside external manual shut-off gas valve, see Figure 27.

SAFETY CONTROLS

AIR FLOW SWITCH (AFS)

The air flow switch, (see Figure 28), is a safety device used to insure that the combustion air blower (fan) is operating and has been designed to monitor the vacuum (negative) pressure within the blower housing. The air flow switch is factory set and is connected upstream of the ignition module. The ignition module does not operate unless the air pressure switch and all safety switches are closed.

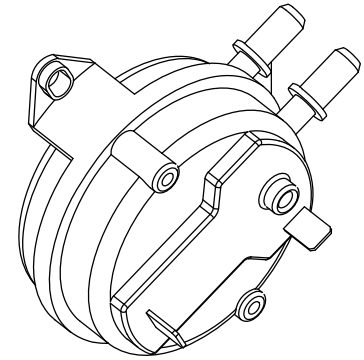



Air Flow Switch Figure 28.

WATER PRESSURE SWITCH

WARNING

Hazardous pressure. Do not bypass the Water Pressure Switch or render it inoperable.

The water pressure switch, (see Figure 29). If the water flow is restricted, the water pressure switch may prevent the burner from firing and cause the “Service System” light to go on. If the light remains on after the filter has been serviced, have a qualified service technician check the system.

For deck-level heater installations, the Water Pressure Switch is factory set at 20.6 kPa (3.00 psi). **NOTE:** See, *Below Pool Level Installation instructions on page 12*. If the pressure switch is .3M (1 ft.) below or above the pool water level, reset the switch so that it is open when the pump is off and closed when the pump is running. Turn the star-wheel on the switch clockwise () to raise setting (heater below the pool) and counterclockwise () to lower the setting (heater above the pool – see Figure 30). Test the switch after resetting.

NOTICE: When the heater is mounted more than 1.5M (5 ft.) above or 1.2M (4 ft.) below the deck level, a Pressure Switch is no longer adequate. A Flow Switch must be installed instead.

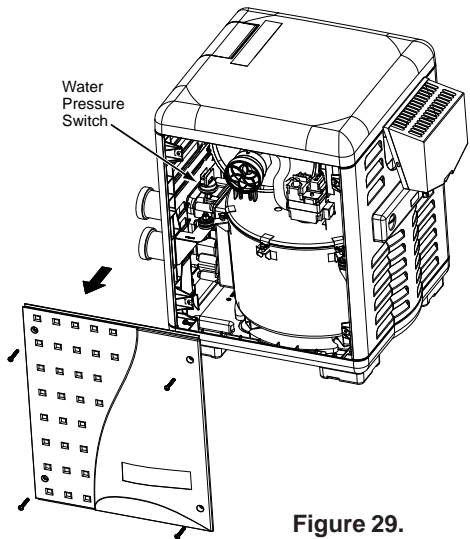

Figure 29.

NOTICE: Heater operation with incorrect Pressure Switch setting may cause operation with no water flow. Operation of the heater without sufficient water flow may severely damage it and **will void the warranty**.

HIGH LIMITS

A “High Limit”, is a safety device that opens the electrical circuit and shuts off the heater based on a water temperature set point within the “High Limit Device”. The MasterTemp series of heaters contains two (2) high limit devices which are located on the main inlet / outlet header.

Turn star wheel **clockwise** to raise pressure set point if pressure switch is more than 1.2M (4 ft.) below water level

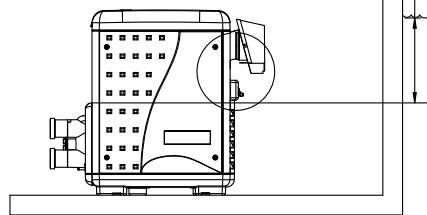

A reference scale is on the back of pressure switch

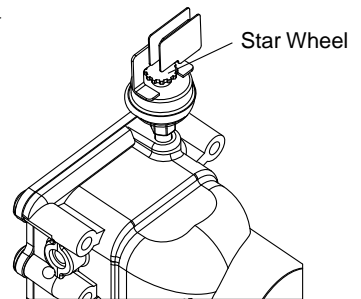

Turn star wheel **counterclockwise** to lower pressure set point if pressure switch is more than 1.5M (5 ft.) above water level

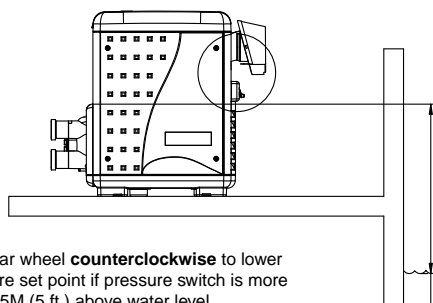

Figure 30.

SAFETY CONTROLS, (cont'd.)

OPERATION OF IGNITION MODULE

The Ignition Module, (see Figure 31), is microprocessor based and operates on 24VAC supplied by the transformer. The control utilizes a microprocessor to continually and safely monitor, analyze, and control the proper operation of the gas flame holder. The module with the presence of the flame sensor, using flame rectification, allows the heater to operate.

OPERATING THE CONTROL PANEL

Use the control panel has five operating switches (buttons):

- POOL ON** Press this button to control the heater operation by the pool temperature setting.
- SPA ON** Press this button to control the heater operation by the spa temperature setting.
- HEATER OFF** Press this button to switch off the heater.
- ▲ TEMP** Press this button to raise the temperature setting.
- ▼ TEMP** Press this button to lower the temperature setting.

To toggle the display between degrees Centigrade (°C) and degrees Fahrenheit (°F):

1. Press the **HEATER OFF** button to switch the heater OFF.
2. Press **▲ TEMP** or **▼ TEMP** for 5 seconds. The display will flash once and change modes (°C to °F or vice versa).
3. Press the **HEATER OFF** button to switch the heater ON.

When either the **▲ TEMP** or **▼ TEMP** buttons are pressed, the digital display will indicate the temperature setting. After five seconds, the display will return to the actual pool/spa temperature.

In addition to the digital temperature display, there are five indicator lights:

The **POOL ON** light indicates the current pool water temperature is controlling the heater operation.

The **SPA ON** light indicates the current spa water temperature is controlling the heater operation.

The **HEATING** light comes on and stays on when the heater's burner chamber is firing. This light should be on whenever the burner is on. The light will blink when the heater is calling for heat but not firing. If this light is on but the burner fails to come on, one of the "service" lights will be on, indicating a fault in the heater system has occurred.

The **SERVICE SYSTEM** light indicates there is insufficient water flow to the heater. If the pump is operating, this usually indicates that the filter and/or skimmers should be cleaned (some filters may require back-washing). If the light remains on after the filter/skimmers have been serviced, the system should be checked by a qualified service technician.

The **SERVICE HEATER** light indicates a fault in the heater or its controls. If this light comes on, shut down the heater (See "TO TURN OFF GAS TO THE APPLIANCE" on page 31), and have a qualified service technician check the system.

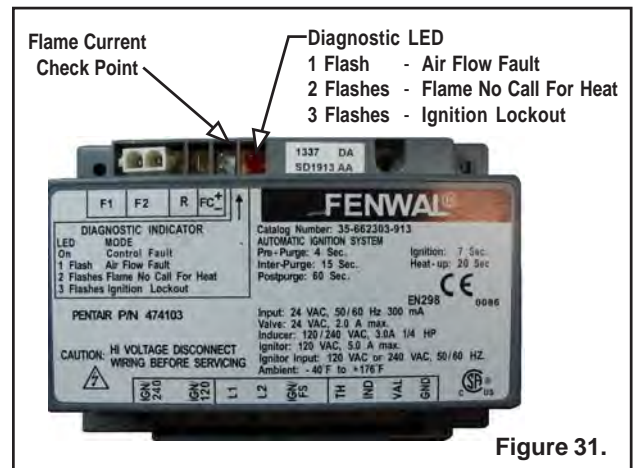

Figure 31.

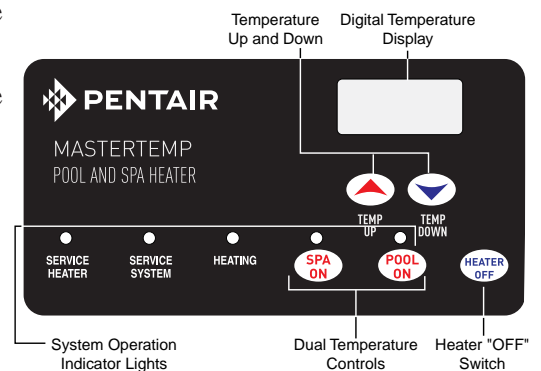

Figure 32.

⚠ WARNING

Risk of explosion or fire causing burns or death if safety interlocks are disabled. DO NOT attempt to operate heater when **SERVICE HEATER** light is on or if blower or burner will not start. Instead, follow instructions under "To Switch Off Gas to the Appliance," and call a qualified service technician to repair the heater.

TEMPERATURE SETTING

The heater comes factory set at 25.6° C (78° F). for the pool mode and 37.8° C (100° F). for the spa mode. Using the up and down arrows, you can set the pool/spa thermostats to a minimum temperature of 18.3° C (65° F.), or a maximum of 40° C (104° F). If you desire to heat only one body of water, the thermostat is capable of an off mode. As an example, if you only wish to heat the spa and not the pool, simply depress and hold the pool down arrow, and the thermostat will lower its setting to 18.3° C (65° F.) then go to an off mode. *See below to change the heater's factory set temperature settings.*

MAXIMUM TEMPERATURE SET POINT

1. Unbolt and remove the door panels (see Figure 33).
2. Access the control panel board on the underside of the top cover. Locate the yellow button on the corner of the control board.
3. Push the **Max. Temp. Set Point** button on the back of the control board (see Figure 34).

The following sequence should happen:

- A. The unit turns on and the **POOL ON** light will turn on.
 - B. Press the **TEMP** or **TEMP** pad (on TOP of the panel) to set maximum pool temperature.
 - C. Wait up to 30 seconds; the **POOL ON** light will turn off and the **SPA ON** light will turn on. To override the time delay, push the **Max. Temp. Set Point** button again.
 - D. Press the **TEMP** or **TEMP** button on the control panel and set maximum spa temperature to 40°C (104° F) or less.
 - E. Wait up to 30 seconds; the **SPA ON** light will turn off and the unit will shut down. To override the time delay, push the **Max. Temp. Set Point** button again.
4. Reinstall the access door panels.

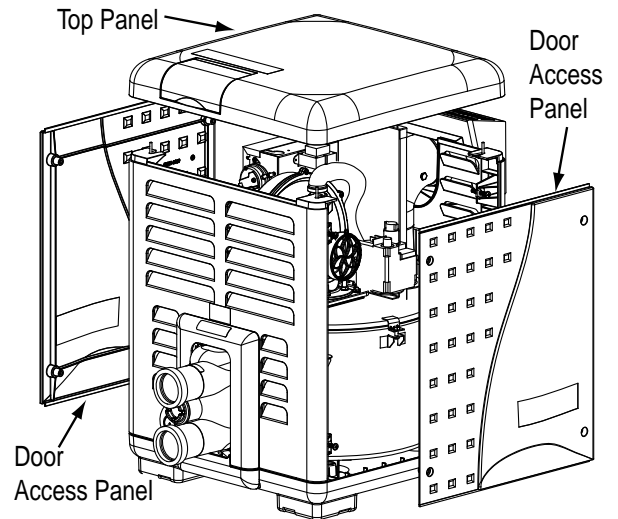

Figure 33.

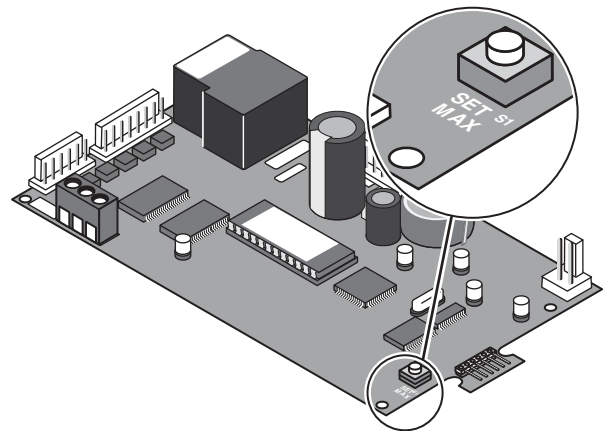

Figure 34.

Troubleshooting Instruction

Initial Troubleshooting

Only qualified, trained service technicians with appropriate test equipment should service the heater. Remember that all parts of the system affect heater operation. Before starting this troubleshooting procedure, make sure that the pump is running correctly, that there are no blockages in the system, that the valves are correctly set and that the time clock is correctly set and is running.

IMPORTANT! READ ME FIRST!

READ THE FOLLOWING CAREFULLY:

1. Check the line voltage to your heater. This heater operates on 240 Volts AC.
2. Remove the covers and check the 12-pin plug in the back of the control box. The plug must match the voltage in the heater circuit.
3. If the 12-pin plug is not plugged into the back of the control box, plug in the **RED** 240 volt plug.

Start here for directions to specific Troubleshooting Chart

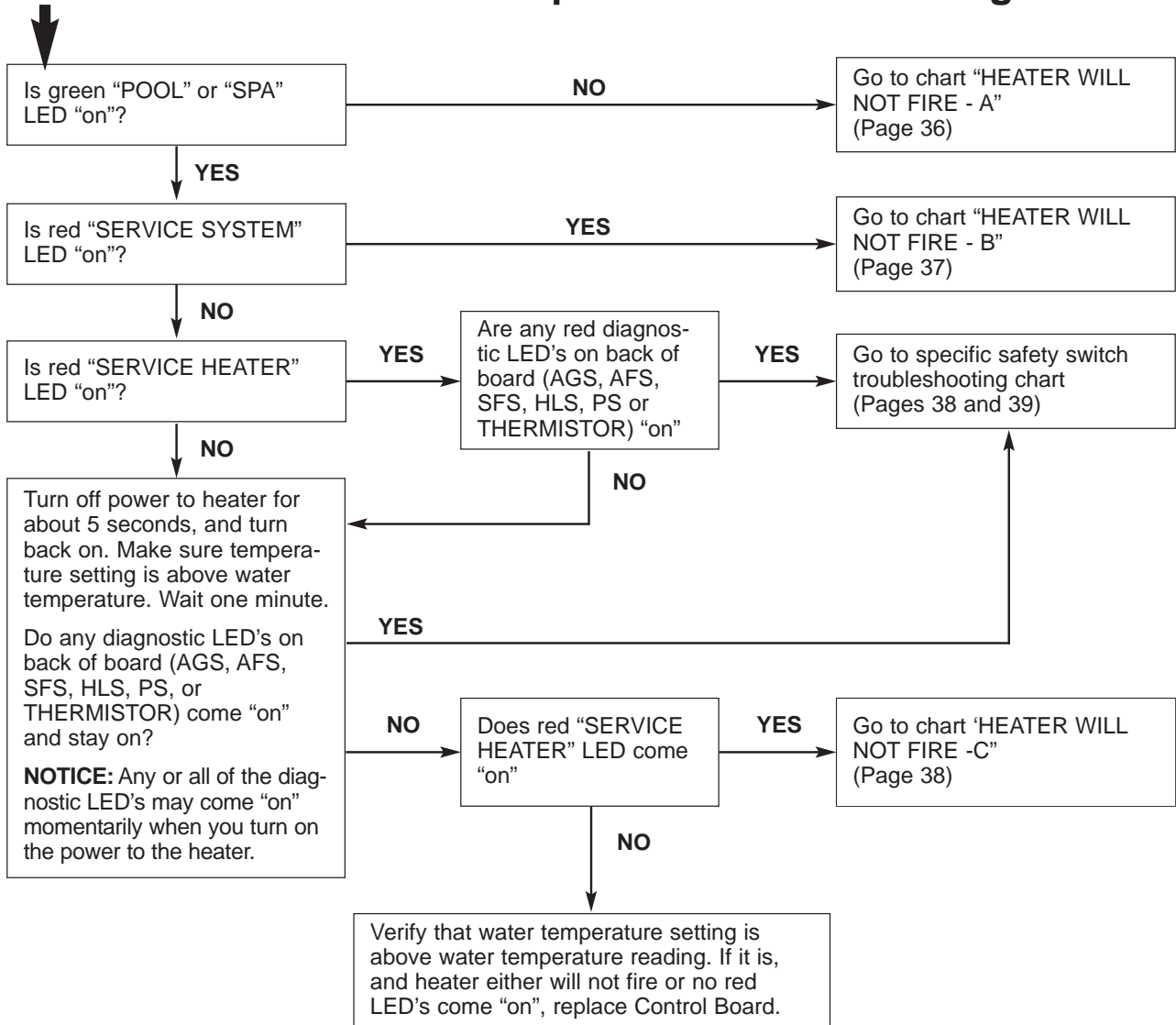

⚠ WARNING Hazardous voltage. Can shock, burn or kill. Disconnect power before servicing any components.

⚠ WARNING Fire and Explosion hazard. Do not jumper switch terminals to remedy a failed safety switch.

Heater Will Not Fire - A

Start

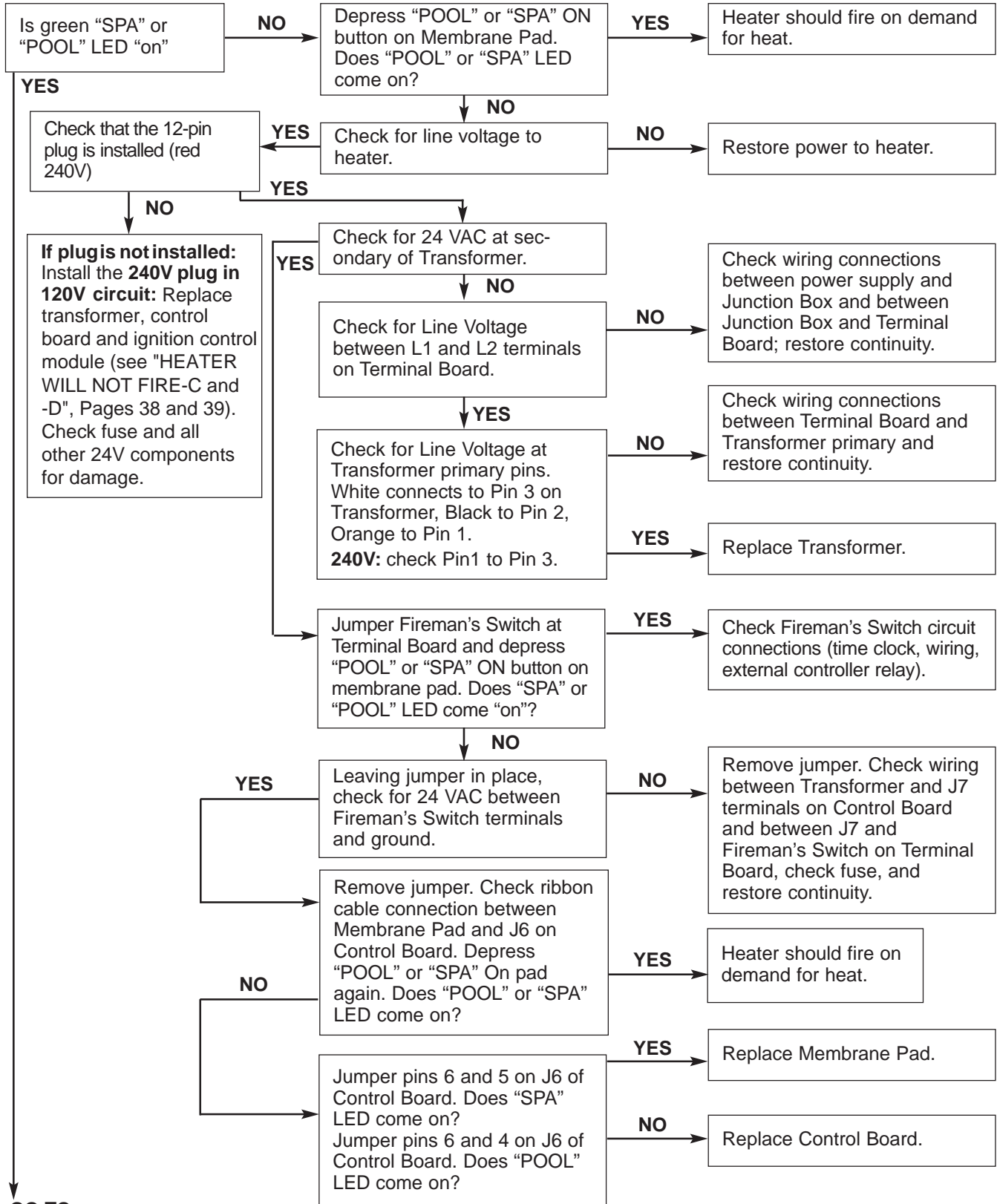

GO TO
 "HEATER WILL NOT FIRE - B"
 Page 37

Heater Will Not Fire - B

Start

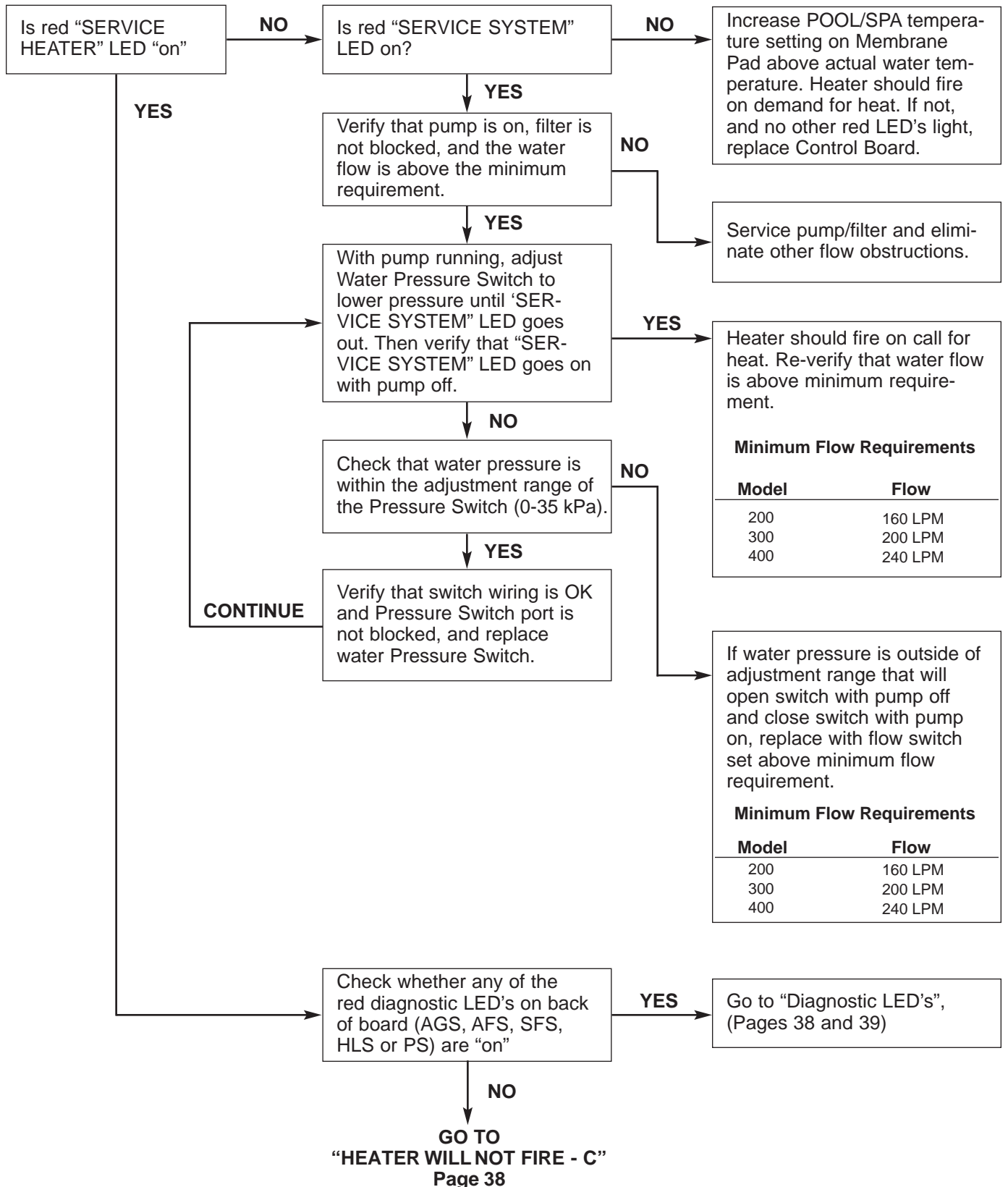

Minimum Flow Requirements

Model	Flow
200	160 LPM
300	200 LPM
400	240 LPM

Minimum Flow Requirements

Model	Flow
200	160 LPM
300	200 LPM
400	240 LPM

Heater Will Not Fire - C

Start

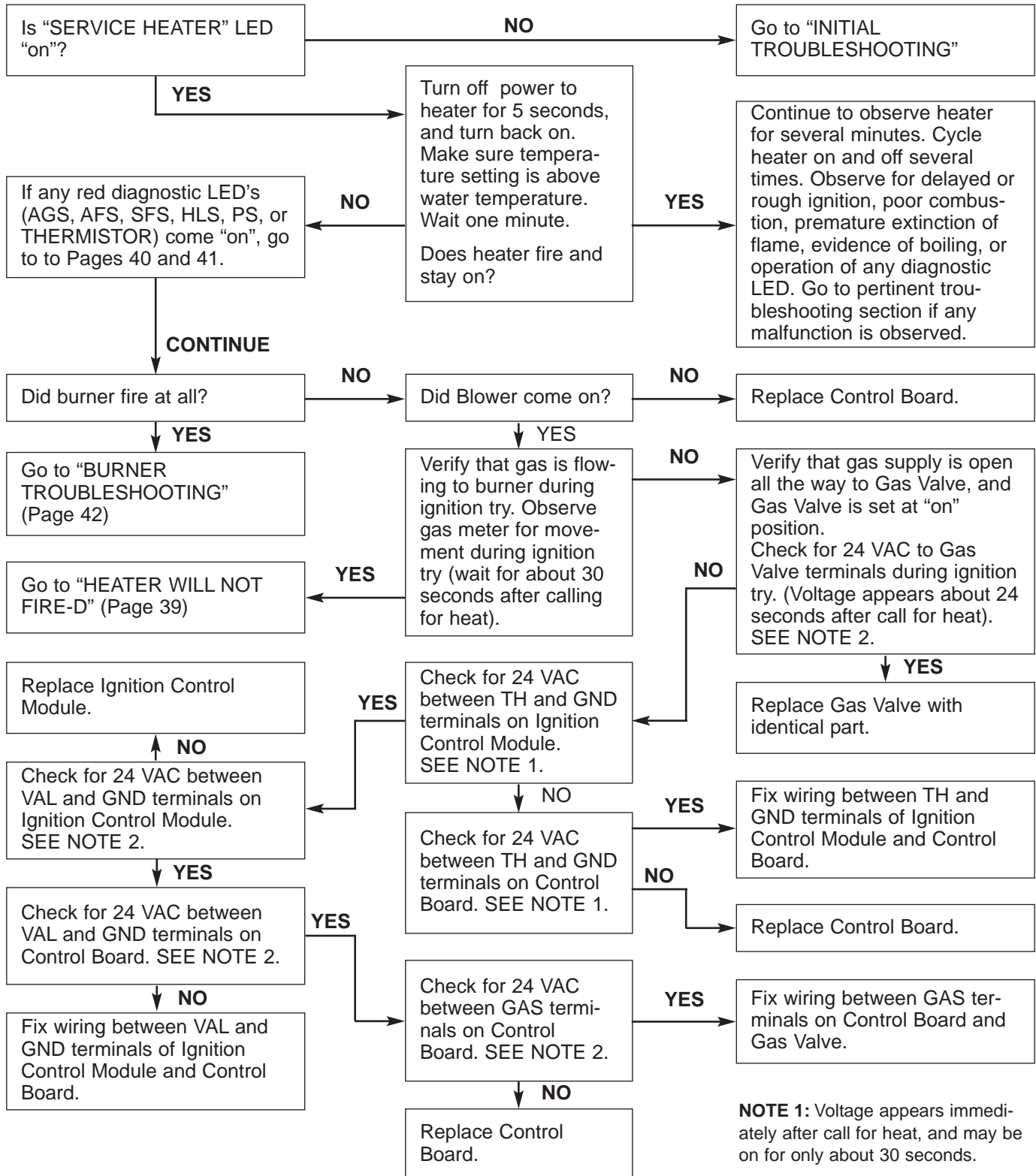

NOTE 1: Voltage appears immediately after call for heat, and may be on for only about 30 seconds.

NOTE 2: Voltage appears about 24 seconds after call for heat, and may be on for only about 7 seconds.

Heater Will Not Fire - D

IMPORTANT! READ ME FIRST!

IMPORTANT! READ ME FIRST!!

If your heater is correctly connected to **240 Volts AC**, the Ignition Control Module (ICM) will convert the 240VAC to an intermittent pulse to the ignitor. Digital meters don't read this type of signal well. (An analog meter will give a better reading than a digital meter). If the ICM is bad, your volt-

meter will read either 0 VAC or 240 VAC. If your ICM is good, your meter will read some voltage between 0 and 240 VAC. Exactly what reading you get will depend on the meter, but with a good ICM, the reading won't be 0 VAC or 240 VAC, but somewhere in between.

Start

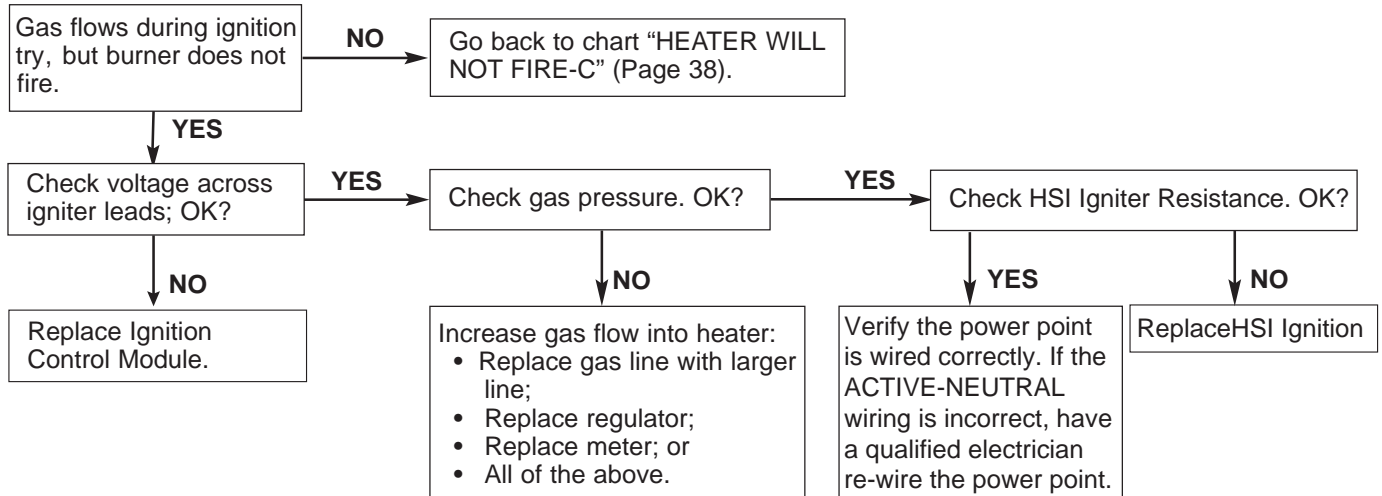

Heater Fires Briefly - E

IMPORTANT! READ ME FIRST!

IMPORTANT! READ ME FIRST!!

If your heater is correctly connected to **240 Volts AC**, the Ignition Control Module (ICM) will convert the 240VAC to an intermittent pulse to the ignitor. Digital meters don't read this type of signal well. (An analog meter will give a better reading than a digital meter). If the ICM is bad, your volt-

meter will read either 0 VAC or 240 VAC. If your ICM is good, your meter will read some voltage between 0 and 240 VAC. Exactly what reading you get will depend on the meter, but with a good ICM, the reading won't be 0 VAC or 240 VAC, but somewhere in between.

Start

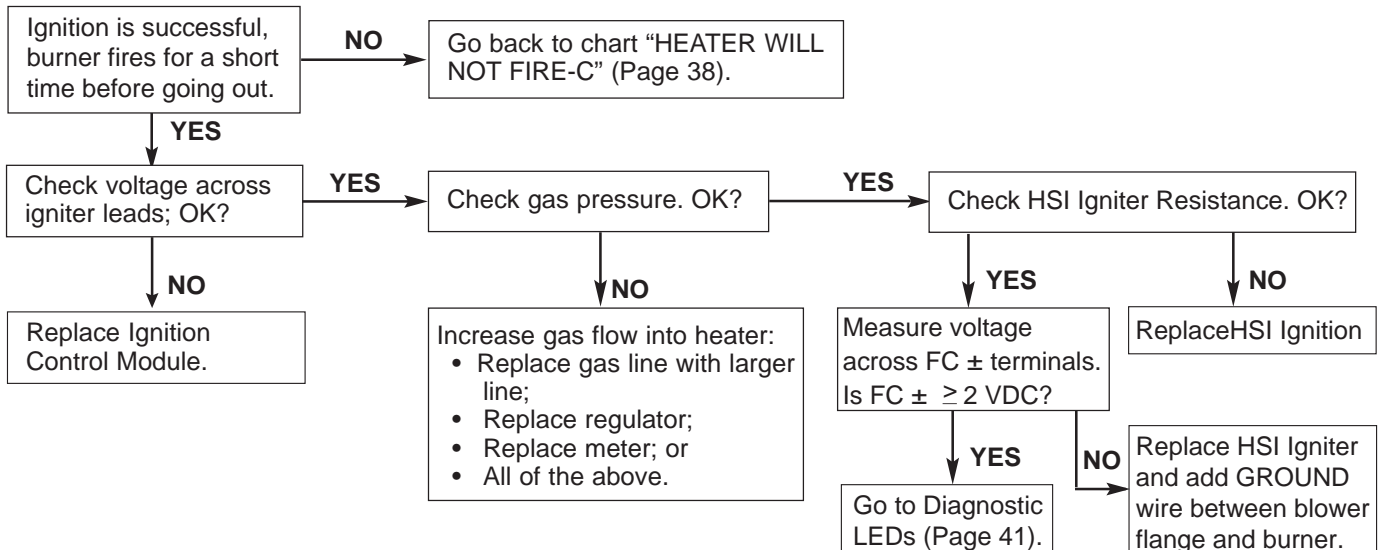

Diagnostic LED's: AGS, AFS, HLS, PS, THERMISTOR

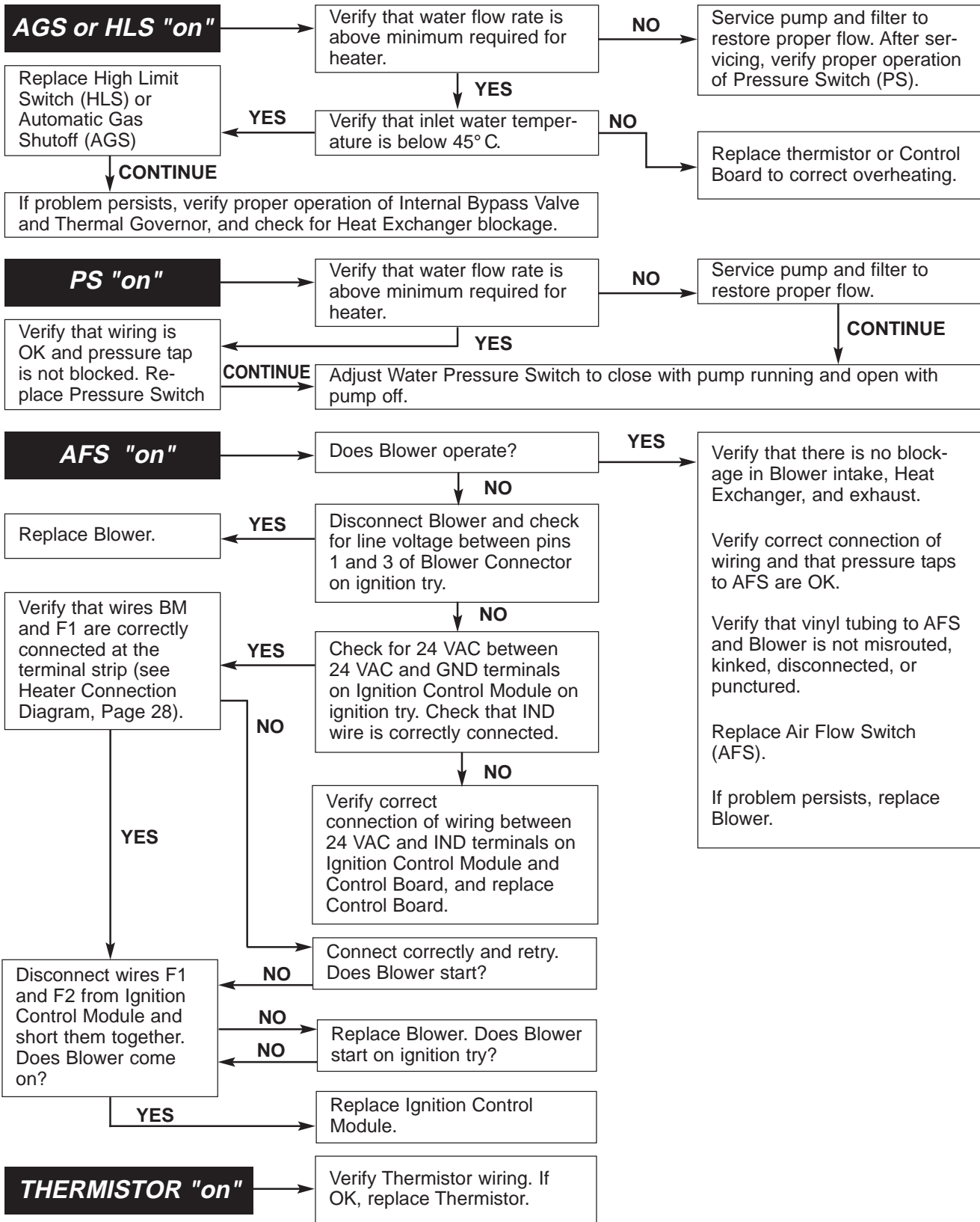

CAUTION Do not jumper a safety switch to remedy a failed switch. **NOTE:** ES1 is a spare and should be jumpered.

Diagnostic LED's: SFS

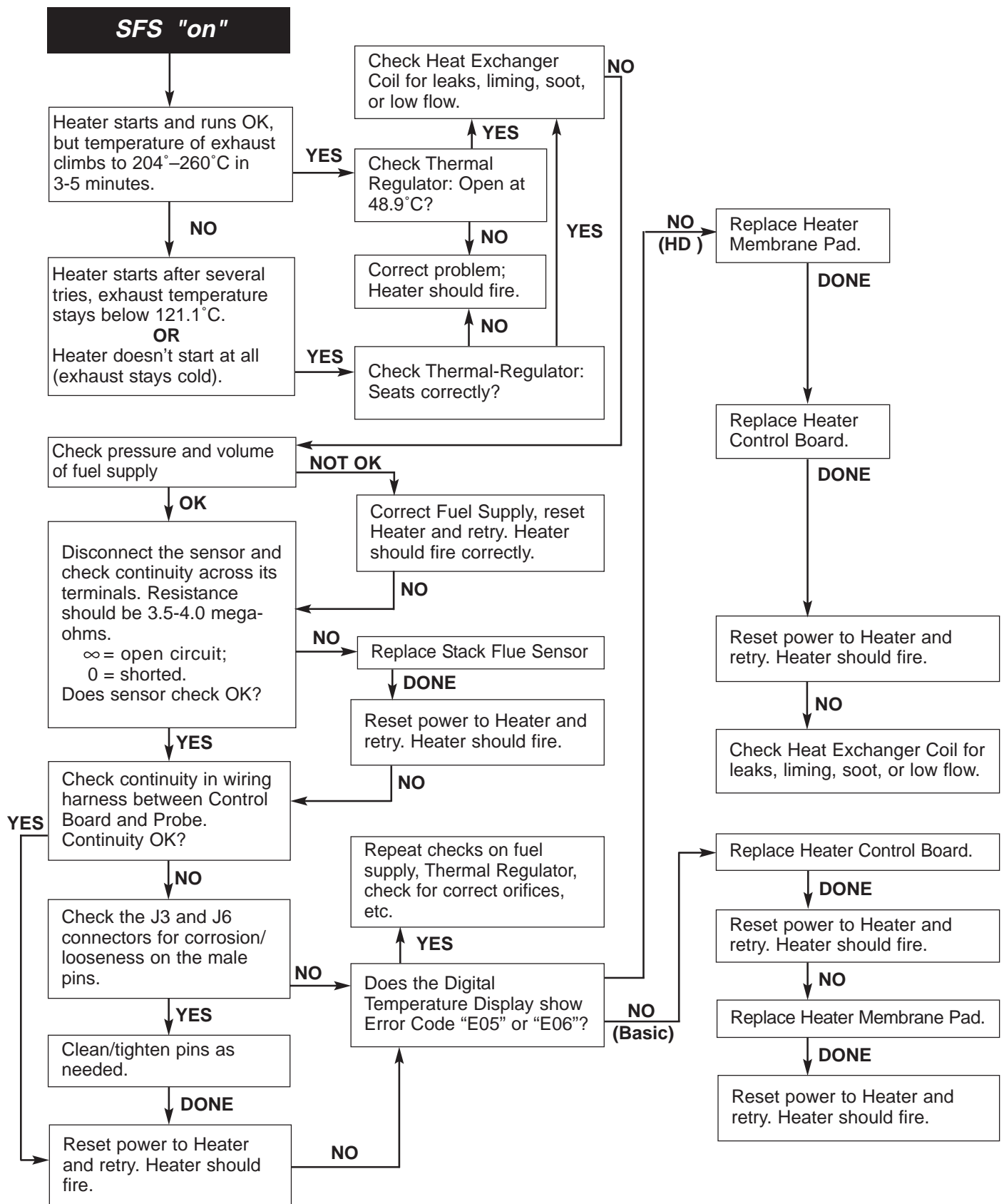

Burner Troubleshooting

SYMPTOM	CAUSE	REMEDY
Loud, high-pitched whine	Flame is too rich.	Verify pressure tap between gas valve and blower inlet. See page 14 and verify that the gas regulator setting is 11 ± 5 Pa. Contact a qualified technician or service agency to replace the gas orifice.
Flame is "fluttery." Exhaust may have acrid smell or burner may fail to stay lit.	Flame is too lean.	See page 14 and verify that the gas regulator setting is 11 ± 5 Pa. Contact a qualified technician or service agency to replace the gas orifice.
Combustion appears normal, but flame does not stay lit.	Flame current is not being sensed.	Check for wet or damaged igniter with low resistance to ground. Replace with new igniter. Verify burner flameholder is properly grounded. Replace Ignition Control Module.

Heat Exchanger Troubleshooting

SYMPTOM	CAUSE	REMEDY
Boiling in heat exchanger. May be accompanied by "bumping" sounds.	Low water flow to heater. Heat exchanger plugged. Bypass valve stuck open. Thermal governor stuck closed.	Service pump and or filter. Service heat exchanger. Correct water chemistry. Service bypass valve. Replace thermal governor.
Sweating.	Thermal governor failed.	Replace thermal governor.

Maintenance Instructions

CARE AND MAINTENANCE

WARNING

Risk of fire or explosion from flammable vapors. Do not store gasoline, cleaning fluids, varnishes, paints, or other volatile flammable liquids near heater or in the same room with heater.

The following maintenance is recommended every six months and at the start of every swimming season:

1. Inspect the heater panels and venting system to make sure that there are no obstructions to the flow of ventilating air or burner exhaust.
2. Keep the area in and around the heater clear and free from combustible materials, gasoline and other flammable vapors and corrosive liquids.
3. If applicable, test the operation of the pressure relief valve by lifting the valve lever. (See below for "PRESSURE RELIEF VALVE" instructions.)
4. Test for proper operation of the pressure switch. (See "WATER PRESSURE SWITCH" for testing instructions.)
5. Check pipe and fittings for cracks or breaks. The combustion air blower is permanently lubricated, and does not require periodic lubrication. The burner does not require maintenance or adjustment by the user. Call a qualified service technician if you suspect that the burner may require maintenance.

CHECKING THE GAS CONTROL VALVE

IMPORTANT NOTICE: This heater is equipped with a combination gas valve that incorporates dual shut-off valves and a negative-pressure regulator, which is factory set with a manifold pressure of $11 \text{ Pa} \pm 5 \text{ Pa}$ below the reference pressure at the blower mixer inlet. If this control valve is replaced, it must be replaced with an identical control, and a gas valve "VENT" tap must be connected to the end cap air orifice as shown in Figure 35.

DO NOT attempt to adjust the gas input by adjusting the regulator setting. The correct gas regulator setting is required to maintain proper combustion and must NOT be altered. CAUTION: The use of Flexible Connectors (FLEX) is NOT recommended unless they are properly sized according to the supplier recommendations for the heater rating.

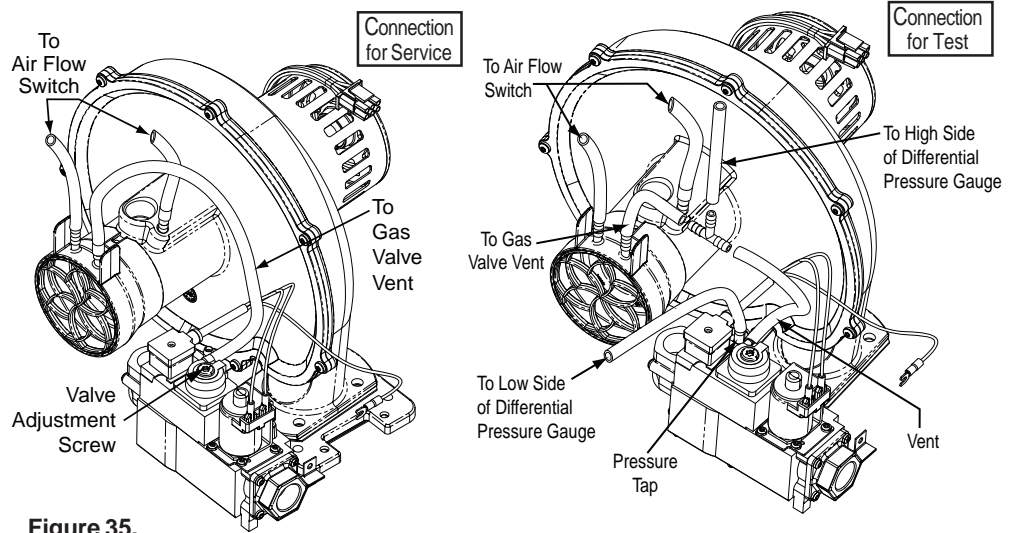



Figure 35.

DE-LIMING THE HEATER

⚠ WARNING	
	Working with muriatic acid can be dangerous. When cleaning elements always wear rubber gloves and eye protection. Add acid to water, do not add water to acid. Splashing or spilling acid can cause severe personal injury and/or property damage.

Should a heater require de-liming, this may be accomplished by circulating a solution of 30% Muriatic Acid. This process should only be performed by a person of sufficient skill. The heater **MUST** be disconnected from the pool plumbing, gas plumbing, and electric. The heater may be placed on its side with the water manifold "up". The diluted muriatic acid may be recirculated until visible bubbles are no longer produced. Before being restored to service, the heater water ways should be completely rinsed with regular tap water.

PRESSURE RELIEF VALVE

Local codes may require installation of a pressure relief valve (PRV). Purchase separately and install a 19 mm pressure relief valve complying with the local Plumbing Codes, having a capacity equal to the Mega Joule (MJ/hr) rating of the heater. The relief pressure of the valve **MUST NOT EXCEED 344 kPa**.

The relief valve must be installed vertically. To install the valve, use a 19 mm x 5 mm brass nipple at the manifold, the two brass elbows and nipples are (user supplied), as illustrated in Figure 36. No valve is allowed to be placed between the manifold adapter and the relief valve.

To avoid water damage or scalding from operation of the relief valve, install a drain pipe in the outlet of the pressure relief valve that will direct water discharging from the valve to a safe place for disposal. Do not install any reducing couplings or valves in the drain pipe. The drain pipe must be installed so as to allow complete drainage from the valve and drain line. **The relief valve should be tested at least once a year by lifting the valve lever.**

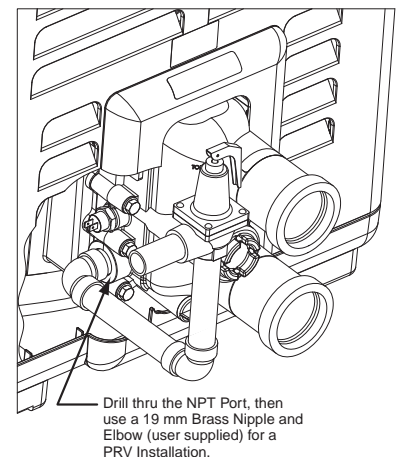

Figure 36.

⚠ WARNING	
Explosion hazard. Any heater installed with restrictive devices in the piping system downstream from the heater, (including check valves, isolation valves, flow nozzles, or therapeutic pool valving), must have a relief valve installed as described above.	

AFTER START-UP

CHECKING WATER FLOW

WARNING

Fire or flooding hazard. If the unit overheats and the burner fails to shut off, follow instructions under “To Turn Off Gas to the Appliance”, page 31, and call a qualified service technician to repair unit.

After start-up, the outlet water pipe should feel slightly warmer than the inlet pipe. If it feels hot, or if you hear the water in the heater boiling, there may not be enough water flow to the appliance. Make sure that the filter is not plugged. If water temperature remains high but the unit continues to operate, turn off the appliance and call your service technician.

SPRING AND AUTUMN OPERATION

If the pool is only used occasionally, lower the pool thermostat to 20° C (68° F) and leave the heater on. This will keep the pool and the surrounding ground warm enough so that the heater should restore the pool to a comfortable temperature within about one day.

WINTER OPERATION

CAUTION

- Operating this heater continuously at water temperatures below 20° C (68° F) will cause harmful condensation and will damage the heater and void the warranty.
- If the heater has been drained for freezing condition, do NOT turn "ON" until the system is circulating water.
- Water trapped in the heat exchanger can result in freeze damage to the exchanger or headers. Freeze damage is specifically not covered by the warranty.
- When starting the heater for the swimming season with a water temperature below 10° C (50° F), the heater may be used to heat the water; however, make sure that the heater operates continuously until the water temperature reaches the heater's minimum setting of 20° C (68° F). During cold weather, if there is no danger of freezing, operate the filter pump continuously even if the heater is not operating. If air temperatures are expected to drop below freezing 0° C (32° F), shut down the heater and winterize it.

For outdoor heaters in freezing climates, shut the heater down and drain it for winter as follows:

1. Turn off electrical supply to the heater and pump.
2. Close the external manual shut-off gas valve (located outside the heater).
3. In colder climates where they may be required, open drain cock located on the bottom of the manifold adapter, and drain the heat exchanger and manifold adapter completely. If heater is below pool water level, be sure to close isolation valves to prevent draining the pool (isolation valves are not required and should not be used on heaters installed above pool water level except when needed for winterizing valves). Assist the draining by blowing out the heat exchanger through the pressure switch fitting with low pressure compressed air (less than 35 kPa or 5 PSI).

WARNING

Explosion hazard. Purging the system with compressed air can cause components to explode, with risk of severe injury or death to anyone nearby. Use only a low pressure (below 35 kPa or 5 PSI), high volume blower when air purging the heater, pump, filter, or piping.

4. Remove the Water Pressure Switch. Plug the port in the manifold to prevent bugs and dirt from getting into the manifold.
5. Drain the plastic inlet/outlet manifold through the outlet pipe. If the pipe does not drain naturally to the pool, install a drain cock in the outlet pipe to drain the manifold.
6. Cover air inlet grate with a plastic bag to prevent bugs, leaves, etc., from getting into the heater.

NOTICE: Water trapped in the heater can cause freeze damage. Allowing the heater to freeze voids the warranty.

To return the heater to service after winterizing:

1. Close drain cock and fittings.
2. Before starting the heater, circulate water through the heater for several minutes until all air noises stop. See also “BEFORE START-UP” (page 30) and “CARE AND MAINTENANCE” (page 43).

(See additional notes under Important Notices in Introduction.)

MAINTAINING POOL TEMPERATURE

To maintain pool temperature, make sure that the heater switch and valving are reset to pool settings after using the spa.

ENERGY SAVING TIPS

1. Keep the pool or spa covered when not in use. This will reduce heating costs, reduce water evaporation, conserve chemicals and reduce load on the filtering system.
2. Reduce pool thermostat to 26° C (78° F) or lower; reduce spa temperature to 38° C (100° F). This is accepted as being the most healthy temperature for swimming by the American Red Cross.
3. Use a time clock to start the filter pump at 6 a.m. or later. The swimming pool loses less heat after daybreak.
4. For pools used only on weekends, lower the thermostat setting by 12° C to 9° C (10° F to 15° F) during the week to reduce heat loss. A properly sized heater will restore normal temperature within one day.
5. Turn the heater off when the pool will not be used for an extended period.
6. Follow a regular program of preventive maintenance for the heater each new swimming season. Check operation of the heater and its controls.

CHEMICAL BALANCE

POOL AND SPA WATER

Your Pentair pool heater was designed specifically for your spa or pool and will give you many years of trouble-free service, provided you keep your water chemistry in proper condition.

Water chemistry should follow good swimming pool water chemistry practices. When using a chlorinator, install it down stream from the heater and at a lower level than the heater outlet. Install a corrosion resistant positive seal “Check Valve”, (P/N R172288), between the heater and the chlorinator to prevent concentrated chemicals from back-siphoning into the heater. Back-siphoning is most likely to occur when the pump stops, creating a pressure-suction differential. Do NOT sanitize the pool by putting chlorine tablets or sticks into the skimmer(s). When the pump is off, this will cause a high concentration of chlorine to enter the heater, which could cause corrosion damage to the heat exchanger.

Three major items that can cause problems with your pool heater are: improper pH, disinfectant residual, and total alkalinity. These items, if not kept properly balanced, can shorten the life of the heater and cause permanent damage.

CAUTION

Heat exchanger damage resulting from chemical imbalance is not covered by the warranty.

WHAT A DISINFECTANT DOES

Two pool guests you do not want are algae and bacteria. To get rid of them and make pool water sanitary for swimming - as well as to improve the water's taste, odor and clarity - some sort of disinfectant must be used.

Chlorine and bromine are universally approved by health authorities and are accepted disinfecting agents for bacteria control.

WHAT IS A DISINFECTANT RESIDUAL?

When you add chlorine or bromine to the pool water, a portion of the disinfectant will be consumed in the process of destroying bacteria, algae and other oxidizable materials. The disinfectant remaining is called chlorine residual or bromine residual. You can determine the disinfectant residual of your pool water with a reliable test kit, available from your local pool supply store.

You must maintain a disinfectant residual level adequate enough to assure a continuous kill of bacteria or virus introduced into pool water by swimmers, through the air, from dust, rain or other sources.

CHEMICAL BALANCE, (cont'd.)

It is wise to test pool water regularly. Never allow chlorine residual to drop below 0.6 ppm (parts per million). The minimum level for effective chlorine or bromine residual is 1.4 ppm.

pH - The term pH refers to the acid/alkaline balance of water expressed on a numerical scale from 0 to 14. A test kit for measuring pH balance of your pool water is available from your local pool supply store; see [Table 10](#).

Muriatic Acid has a pH of about 0. Pure water is 7 (neutral). Weak Lye solution have a pH of 13-14.

RULE: 7.4 to 7.6 is a desirable pH range. It is essential to maintain correct pH, see [Table 10](#).

If pH becomes too high (over alkaline), it has these effects:

1. Greatly lowers the ability of chlorine to destroy bacteria and algae.
2. Water becomes cloudy.
3. There is more danger of scale formation on the plaster or in the heat exchanger tubing.
4. Filter elements may become blocked.

If pH is too low (over acid) the following conditions may occur:

1. Excessive eye burn or skin irritation.
2. Etching of the plaster.
3. Corrosion of metal fixtures in the filtration and recirculation system, which may create brown, blue, green, or sometimes almost black stains on the plaster.
4. Corrosion of copper tubes in the heater, which may cause leaks.
5. If you have a sand and gravel filter, the alum used as a filter aid may dissolve and pass through the filter.

CAUTION: Do not test for pH when the chlorine residual is 3.0 ppm or higher, or bromine residual is 6.0 ppm or higher. See your local pool supply store for help in properly balancing your water chemistry.

RULE: Chemicals that are acid lower pH. Chemicals that are alkaline raise pH.

ALKALINITY High or Low:

"Total alkalinity" is a measurement of the total amount of alkaline chemicals in the water, and control pH to a great degree. (It is not the same as pH which refers merely to the relative alkalinity/acidity balance.) Your pool water's total alkalinity should be 100 - 140 ppm to permit easier pH control. A total alkalinity test is simple to perform with a reliable test kit. You will need to test about once a week and make proper adjustments until alkalinity is in the proper range. Then, test only once every month or so to be sure it is being maintained. See your local pool dealer for help in properly balancing the water chemistry.

WATER CHEMISTRY PARAMETERS

Table 10.

Disinfectant levels	Minimum	Ideal	Maximum
Free Chlorine, ppm	1.0	2.0-3.0	4.0
Salt, ppm	2000	3200	5000
Combined Chlorine, ppm	None	None	0.2
Bromine, ppm	2.0	4-6	10.0
Other Sanitizers	Levels not established. Consult local health department before use.		
Chemical Values			
pH	7.2	7.4-7.6	7.8
Total Alkalinity (Buffering), ppm as CaCO ₃	60	80-100	180
Total Dissolved Solids, ppm	N/A	N/A	1,500 ppm > TDS at startup*
Calcium Hardness, ppm, as CaCO ₃	150	200-400	500
Heavy Metals	None	None	None
Biological Values			
Algae	None	None	None
Bacteria	None	None	Refer to Local Code

NOTICE: Failure to adhere to the listed water chemistry parameters may result in premature failure of the heat exchanger and will void the warranty. *Start-up TDS includes source water TDS and any other inorganic salt added at start-up.

Note: DO NOT use a metal ionizer with the MasterTemp heater.

MASTERTEMP REPLACEMENT PARTS

For complete Electrical System parts breakdown (Key Nos. 1 through 4), see Page 51.

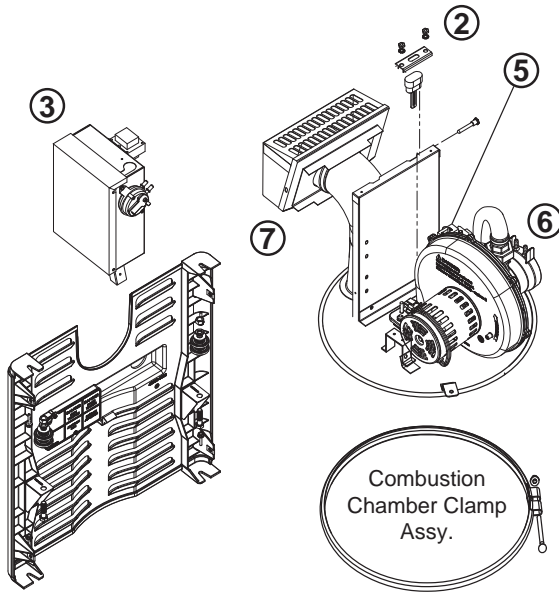
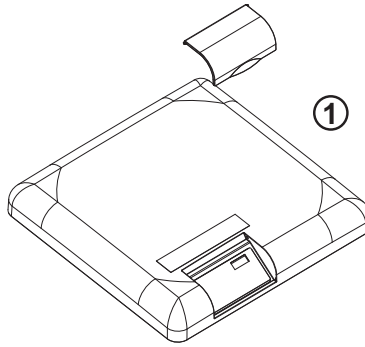

For complete Burner System parts breakdown (Key Nos. 5 through 7), see Page 49.

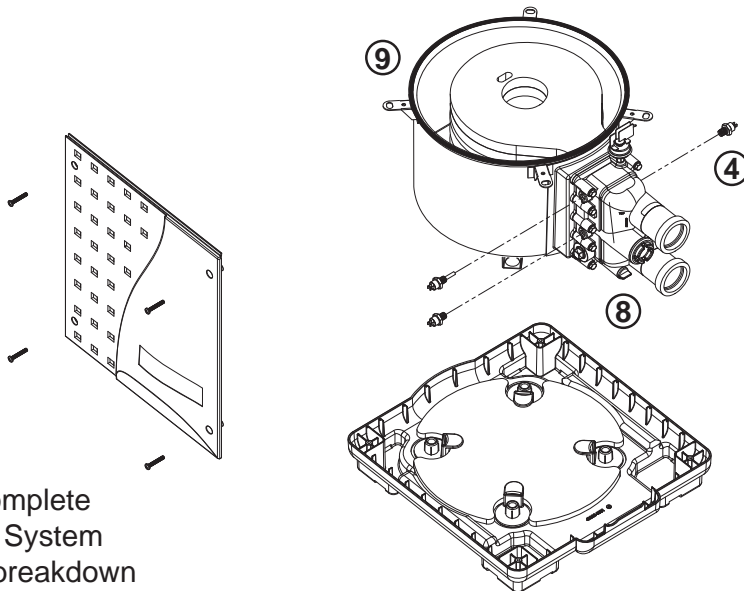
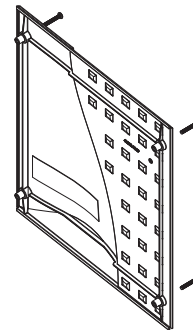

For complete Water System parts breakdown (Key Nos. 8 through 9), see Page 50.

Repair Parts are available from your Pentair dealer.
 If your dealer cannot supply you, call Customer Support [AU/NZ] at 1800 664 266 – [USA] at 1-800-831-7133.

MASTERTEMP REPLACEMENT PARTS

For Heater mounting bolts and clamps, purchase separately Bolt Down Bracket Kit, Part No. 460738.

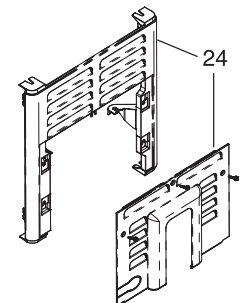
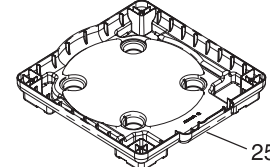
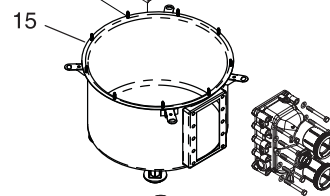
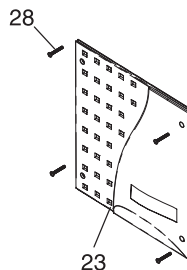
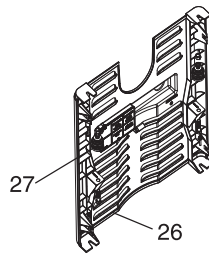
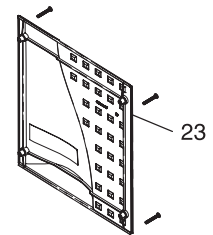
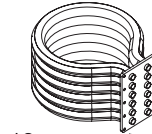
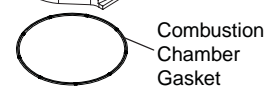
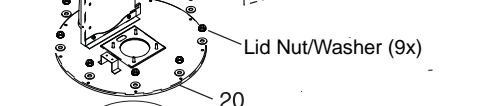
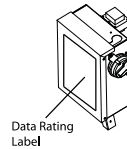
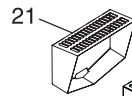
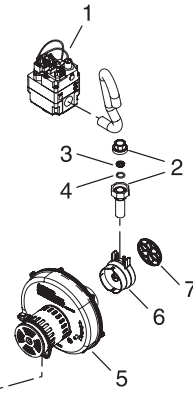
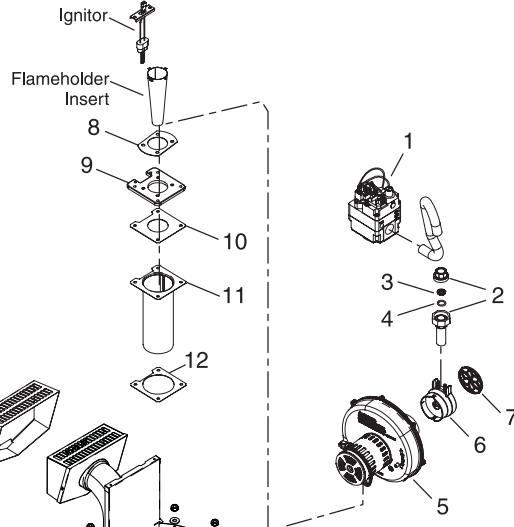
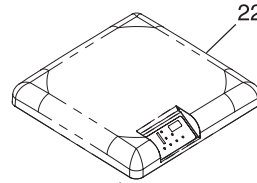
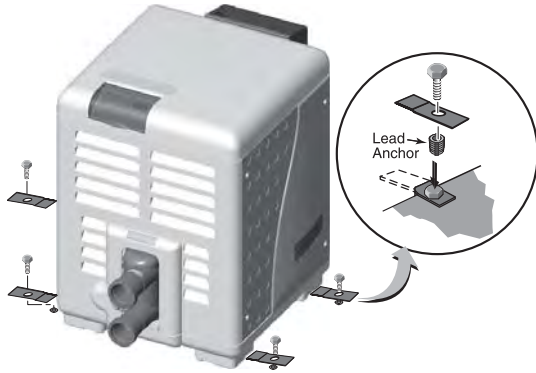

CLAMP LID TUB DESIGN

Combustion Chamber Clamp Assy.

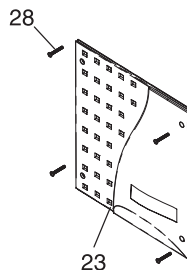
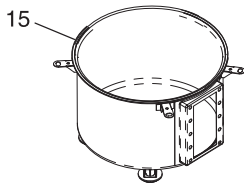
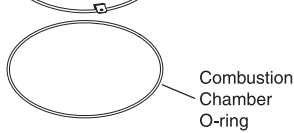
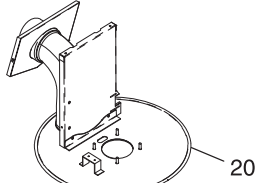
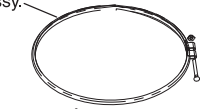

For heaters manufactured between 1/12/2009 and 10/31/2013 (clamp lid tub design)
 Note: Kits also include Clamp Assembly, O-Ring and Silicon Tube (see page 49)

MASTERTEMP REPLACEMENT PARTS

REPAIR PARTS – BURNER SYSTEM

Key No.	Part Description	Qty.	Model		
			200NA 200LP	300NA 300LP	400NA 400LP
1	Gas Valve Assembly [Australia]	1	474133Z	474133Z	474133Z
2	19 mm Union	2	38404-4097S	38404-4097S	38404-4097S
3	Gas Orifice	1			
4	Gas Orifice O-Ring	1			
	• Gas Orifice Kit – NG (Incl. Key Nos. 3 and 4)†		474136	474135	474134
	• Gas Orifice Kit – LPG (Incl. Key Nos. 3 and 4)†		474139	474138	474137
	• NG to LPG Conversion Kit (Incl. Key Nos. 3 and 4)†		474142	474141	474140
	• LPG to NG Conversion Kit (Incl. Key Nos. 3 and 4)†		474145	474144	474143
5	Air Blower [50 Hz]	1	474104Z	474104Z	474104Z
6	Air Orifice	1	474107Z	474106Z	474105Z
7	Air Orifice Grill	1	42001-0114S	42001-0114S	42001-0114S
	• Blower/Adapter Plate Gasket Kit (Includes Key Nos. 8, 9, 10, 12)	1	77707-0011	77707-0011	77707-0011
	• Flameholder Kit (Includes Key Nos. 10, 11, 12, 13 and on 300 & 400 Models Only- Flameholder Insert)	1	77707-0202	77707-0203	77707-0204
8	Blower/Adapter Plate Gasket*	1			
9	Blower Adapter Plate*	1			
10	Flameholder/Adapter Plate Gasket*	1			
11	Flameholder Assembly*	1			
12	Flameholder/Combustion Chamber Gasket*	1			
13	Flameholder Insulation Cap*	1			
	• Flameholder Insert*	1			
14	Condensate Evaporator Plate*	1			
15	One Piece Metal Chamber/Combustion Chamber Assembly	1	42001-0200S	42001-0200S	42001-0200S
	• Insulation Kit (Includes Key Nos. 13, 14, 16, 17, 18 and 19)	1	474957**	474957**	474957**
	• Bottom Outer Insulation Blanket*	1	77707-0008	77707-0008	77707-0008
16	25.4 mm Bottom Inner Insulation*				
17	25.4 mm Top Insulation*				
18	Top Outer Insulation Blanket*				
19	One Piece Metal Elbow/Combustion Chamber Cover Assembly				
	• Combustion Chamber O-Ring Kit	1	42001-0214S 474958**	42001-0214S 474958**	42001-0214S 474958**
			474952 474201**	474952 474201**	474952 474201**
20	Metal Vent Cover Cover Assembly	1	474172Z	474172Z	474172Z
21	Heater Top	1	42002-0034Z	42002-0034Z	42002-0034Z
22	Side Panel {Service Panel}	1	42002-0039Z	42002-0039Z	42002-0039Z
23	Side Panel {Manifold}	1	42002-0033Z	42002-0033Z	42002-0033Z
24	Heater Bottom	1	42002-0031Z	42002-0031Z	42002-0031Z
25	Side Panel {Flue Stack}	1	42002-0032Z	42002-0032Z	42002-0032Z
26	J-Box Cover	1	42002-0041Z	42002-0041Z	42002-0041Z
27	Screw Kit, Panel	1	474292	474292	474292
	• Combustion Air Intake Duct Connection Kit	1	461031	461031	461031

(*) Not available separately.

(**) For heaters manufactured between 1/12/2009 and 10/31/2013 (clamp lid tub design) - Note: Kits also include Clamp Assembly, O-Ring and Silicon Tube.

† Not included with heater. Order separately.

MASTERTEMP REPLACEMENT PARTS

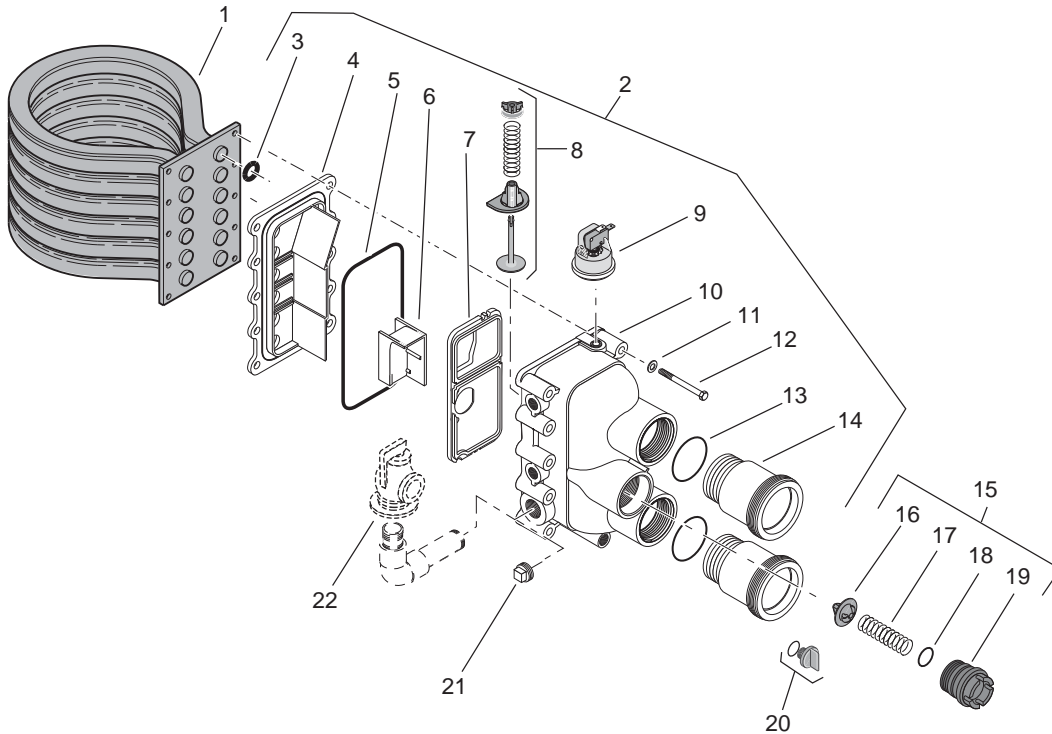

REPAIR PARTS – WATER SYSTEM

Key No.	Part Description	Qty.	Model		
			200NA 200LP	300NA 300LP	400NA 400LP
1	Tube Sheet Coil Assembly Kit (NA – HD Series) (Includes Key No.3)	1	77707-0242	77707-0243	77707-0244
2	Manifold Kit (Includes Key Nos. 3-14, 21, and Key Nos. 5-7, 17 in "Electrical System", Page 51)	1	474391	474392	475267
3	Coil/Tubesheet Sealing O-Ring Kit	()	77707-0117(6)	77707-0118(10)	77707-0119(12)
4	Manifold Bottom Plate	1			
5	Manifold O-Ring	1			
•	O-Ring Kit (Incl. Key Nos. 3, 5)	1	77707-0120	77707-0120	77707-0120
6	Manifold Insert*	1			
7	Manifold Baffle Plate	1			
8	Manifold Bypass Valve	1			
9	Water Pressure Switch	1	42001-0060S	42001-0060S	42001-0060S
10	Manifold	1			
11	5/16" Washer, S.S.	10			
12	5/16"-18 x 2-3/4" Hex Cap Screw	10			
13	Connector Tube O-Ring	2			
14	Connector Tube Kit (Includes 1 Connector Tube and 1 O-Ring)	2	77707-0017	77707-0017	77707-0017
15	Thermal Regulator Kit (Incl. Key Nos. 16, 17, 18, 19 and Spring Clip)	1	77707-0010	77707-0010	77707-0010
16	Thermal Regulator (Includes Spring Clip)	1	38000-0007S	38000-0007S	38000-0007S
17	Thermal Regulator Spring	1			
18	Thermal Regulator Cap O-Ring	1	35505-1313	35505-1313	35505-1313
•	Thermal Regulator Spring Clip	1			
19	Thermal Regulator Cap	1			
20	Drain Plug	1	U178-920P	U178-920P	U178-920P
21	3/4" Pipe Plug	1	U78-60ZPS	U78-60ZPS	U78-60ZPS
22	Pressure Relief Valve (Recommended - Purchase Separately)	1	460925	460925	460925
•	Barrel Union Kit	2	801245	801245	460925
•	Barrel Union O-Ring	1	702192	702192	702192

* Not available separately.

• Not illustrated.

MASTERTEMP REPLACEMENT PARTS

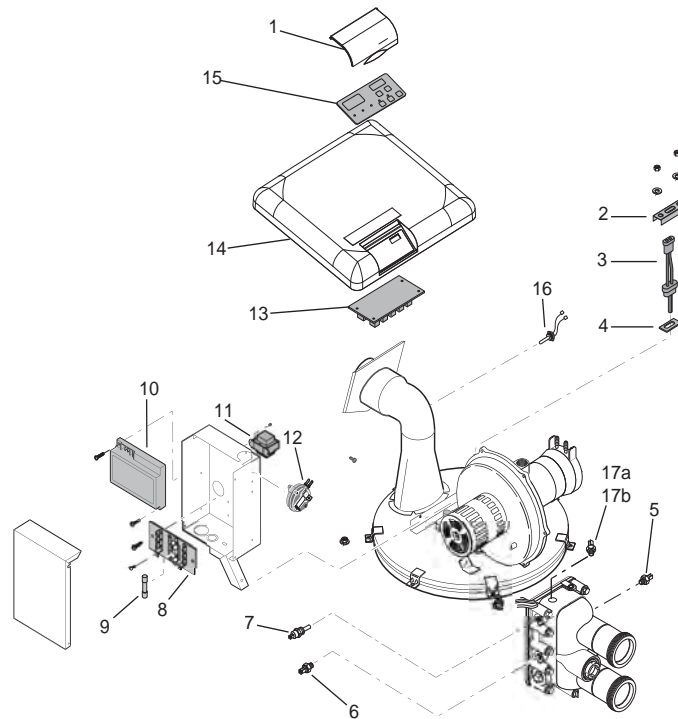

REPAIR PARTS – ELECTRICAL SYSTEM

Key No.	Part Description	Qty.	Model		
			200NA 200LP	300NA 300LP	400NA 400LP
1	Heater Display Cover	1	42002-0035	42002-0035	42002-0035
2	Igniter Bracket	1	42001-0030S	42001-0030S	42001-0030S
3	Igniter/Igniter Gasket Kit Incl. Key Nos. 3 and 4)	1	77707-0054	77707-0054	77707-0054
4	Igniter Gasket	1	42001-0066S	42001-0066S	42001-0066S
5	Automatic Gas Shutoff Switch (AGS)	1	42002-0025S	42002-0025S	42002-0025S
6	High Limit Switch	1	474171Z	474171Z	474171Z
7	Thermistor	1	42001-0053S	42001-0053S	42001-0053S
8	Terminal Board	1	42001-0056S	42001-0056S	42001-0056S
9	Fireman's Switch Fuse (31.75 mm X 6.35 mm)	1	32850-0099	32850-0099	32850-0099
10	Fenwal Ignition Control Module	1	474103Z	474103Z	474103Z
11	Transformer, 120/240V	1	42001-0107S	42001-0107S	42001-0107S
12	Air Flow Switch	1	42001-0061S	42001-0061S	42001-0061S
13	Control Board Kit (NA, LP Series)	1	42002-0007S	42002-0007S	42002-0007S
•	Heater Wiring Harness	1	474163Z	474163Z	474163Z
14	Heater, Top	1	42002-0034Z	42002-0034Z	42002-0034Z
15	Membrane Pad (NA, LP Series)	1	472610Z	472610Z	472610Z
16	Stack Flue Sensor	1	42002-0024S	42002-0024S	42002-0024S
17a	Inlet Temperature Control Switch (1/8" thread)	1	474363Z	474363Z	474363Z
17b	Inlet Temperature Control Switch (1/4" thread)	1	475147Z	475147Z	475147Z

If you have any questions about use of this product or safety precautions, contact Customer Service and Technical Support at 1300.137.344 – AUS, 0800 654 112 - NZ or USA (800) 831-7133 or visit www.pentairpool.com

SAVE THESE INSTRUCTIONS



1-21 Monash Drive, Dandenong South, Victoria 3175 – Australia • 1300.137.344 • Fax 1800 006.668

www.pentairpool.com.au

All Pentair trademarks and logos are owned by Pentair or by one of its global affiliates. Pentair Aquatic Systems™, MasterTemp™, IntelliTouch™, EasyTouch™, are trademarks and/or registered trademarks of Pentair Water Pool and Spa, Inc. and/or its affiliated companies in the United States and/ or other countries. Unless expressly noted, names and brands of third parties that may be used in this document are not used to indicate an affiliation or endorsement between the owners of these names and brands and Pentair Water Pool and Spa, Inc. Those names and brands may be the trademarks or registered trademarks of those third parties. Because we are continuously improving our products and services, Pentair reserves the right to change specifications without prior notice. Pentair is an equal opportunity employer.

© 2016 Pentair Water Pool and Spa, Inc. All rights reserved. This document is subject to change without notice.



P/N 474131 REV L 6/2016